



DC-640-H

**Double Chamber Vacuum Packaging
Machine**

Operation Manual

Version 6.9.1

1915 E. Acacia Street, Ontario, CA91761, U.S.A

TEL : 1-909-923-3888

FAX : 1-909-923-3588

<http://www.promarksvac.com>

S/N:

QC SIGNATURE:

TABLE OF CONTENTS

1. SAFETY	1
1.1 SAFETY RECOMMENDATIONS	1
1.2 PERSONAL SAFETY	2
1.3 FOOD SAFETY	3
2. INSTALLATION	4
2.1 UNPACKING	4
2.2 MOVING THE MACHINE	4
2.3 MACHINE SPECIFICATIONS	5
2.4 ENVIRONMENT REQUIREMENTS	5
2.5 CHECK OIL LEVEL	6
2.6 POWER CONNECTION	6
2.7 VACUUM PUMP ROTATION	6
3. OPERATION	7
3.1 VACUUM SETTING GUIDELINES	7
3.2 BASIC OPERATING INSTRUCTIONS	7
3.3 OPTIONAL DEVICE	7
3.3.1 GAS FLUSHING UNIT	7
3.4 OPERATION OF THE PNC-01 DIGITAL CONTROL PANEL	8
3.4.1 STANDARD MACHINE – BASIC INSTRUCTIONS	8-9
3.4.2 SETTING THE PARAMETERS FOR THE OPTIONAL SETTINGS.....	10-12
4. MAINTENANCE	13
4.1 BASIC MAINTENANCE	13
4.1.1 DAILY VISUAL INSPECTION	13
4.1.2 DAILY CLEANING	14
4.2 VACUUM PUMP MAINTENANCE	14
4.3 SEAL BAR MAINTENANCE	14-16
4.4 MAINTENANCE INTERVAL CHART	17
5. TROUBLESHOOTING	18
5.1 OPTIONAL DEVICE	18
5.2 25 PIN D TYPE TERMINAL WIRING CONNECTION INSTRUCTIONS	19
5.3 PNEUMATIC DIAGRAM	20
5.4 ELECTRICAL DIAGRAM (FB).....	21
6. FABRICATION	22
6.1 BODY DIAGRAM	23-24
6.2 WORKING BED (BOTTOM)	25-27
6.3 SEALING BAR/ CUSHION BAR CONFIGURATIONS	28
6.3.1 CUSHION BAR (FB)	28-29
6.4 CHAMBER LID, TOP DIAGRAM	30-31
6.5 SEALING BAR CONFIGURATIONS, TOP	32
6.5.1 SEALING BAR (FB)	32-34
6.6 ELECTRICAL BOXES (FB).....	35-37

Explanation of Abbreviations

(FB) Standard Front / Back

(FBG) Front /Back with Gas

(FBPK) Front / Back with Perforating Knife

(FBPKG) Front / Back with Perforating Knife + Gas

(FBTB) Front / Back with Top / Bottom Seal

(FBTBG) Front / Back with Top / Bottom Seal +Gas

(FBTBPK) Front / Back with Top / Bottom Seal + Perforating Knife

(FBTBPKG) Front/ Back with Top / Bottom Seal + Perforating Knife + Gas

General

This owner's manual contains information relating to your Promax machine. It will provide you with basic information concerning both operation and maintenance of your new machine. Please read it carefully as failure to do so may result in bodily injury and / or damage to the equipment.

Please fill in the information below. You will find the information on the bill of lading and on the machines identification tag. You will need this information when ordering replacement parts or making technical inquiries.

Model # _____

Serial # _____

Ship Date: _____

Owner: _____

Location: _____

1. SAFETY

1.1 SAFETY RECOMENDATIONS

Unsafe practices or unauthorized modifications of machine could result in accidents or property damage.

For safe installation, operation, handling and maintenance, please strictly follow the simple safety rules stated below and take precautions. Failure to follow these safety rules and take necessary precautions can result in serious injury or death as well as cause damage to the equipment.

- 1) Never operate or service your Promax / Promarks machine until you have read this manual completely and understand it fully.
- 2) All adjustments and repairs must be carried out only by qualified technicians or maintenance personnel.
- 3) No service work should be attempted until the machine's power has been turned off. All proper lock out / tag out procedures should be followed.
- 4) Do not put tools, parts or other foreign objects on or into the machine.
- 5) Always keep the machine clean, lubricated and in good working condition.
- 6) To provide protection against the risk of electrical shock the power connection must be properly grounded at all times.
- 7) The machine should always be operated on a flat stable surface.
- 8) A certified electrician should be employed to install the permanent electrical connections for your new machine.

1.2 PERSONAL SAFETY

Please read and understand this operation manual before using this equipment. Failure to follow the operating instructions may result in personal injury or damage to the machine.

The following procedures and guidelines must be observed to avoid problems that can result in property damage, personal injury or death. If you have any questions regarding this information please contact Promax /Promarks, Inc. Service Department at (909) 481-3338.

Hazardous Voltage: DANGER

Electrical power must be disconnected and locked out before servicing or cleaning of the machine. Do not remove any panels before power has been disconnected and locked out due to the risk of electric shock hazard.

Explosion Hazard: DANGER

When utilizing the gas flush feature (optional) do not use any gas mixture with greater than 22% oxygen content.

Blade Hazard: WARNING

If your machine is equipped with either a Perforating Knife System (optional) or a Precut Knife System (optional) then do not remove or install blades without wearing protective gloves. These blades are SHARP, use care when handling.

Signal words used in classifying potential hazards are defined as follows:

DANGER: Indicates an imminently hazardous situation, which if not avoided, may result in death or serious injury.

WARNING: Indicates a potentially hazardous situation, which if not avoided, could result in serious injury.

CAUTION: Indicates a potentially hazardous situation, which, if not avoided, may result in minor to moderate injury. Caution also indicates actions that may cause property damage.

1.3 FOOD SAFETY

While many Promax / Promarks machines are used in applications involving vacuum packaging and vacuum cooking, there are inherent risks associated with these techniques that can result in serious illness or death to the consumer of the food product. Therefore if you are using your machine for food applications, you must consult a qualified food technician or specialist in vacuum / modified atmosphere (M.A.P.) to review the safety of your application.

GAS FLUSH

If your machine is equipped with gas flush (optional) and your application involves the use of gas flush to extend the shelf life of your product you must consult a qualified food technician or specialist to review your application and develop a suitable gas mixture for your package. Further you must perform quality control and gas analysis on your final M.A.P. package.

CLEANING

Every environment and application is different; therefore Promax / Promarks cannot provide cleaning procedure instructions that will guarantee microbiological sanitation. Therefore Promax / Promarks recommends that the purchaser of these machines consult with a sanitation expert to review your procedures for cleaning the machine while operating in your environment and with your specific product to develop a robust cleaning schedule and methodology, followed by bacterial testing to ensure satisfactory cleaning is achieved.

2.INSTALLATION

2.1 UNPACKING

- Carefully remove the cardboard outer shell by cutting the retaining straps then removing the top and then the side panels.
- Inspect the machine carefully for any hidden shipping damage. Notify the shipping company right away if any damage is observed.
- Remove the machine from the wooden skid. This can be done by two people on the smaller table top machines. However an approved fork lift will be required for the larger SC and DC models. **Important note:** Refer to the Moving the Machine Section below.
- Wipe down the outside of the machine.

2.2 MOVING THE MACHINE

Promax chamber style vacuum packaging machines are available in three basic designs, TC (Table Top), SC (Free Standing Single Chamber) and DC (Double Chamber). Recommendations for the movement of all three types are listed below.

TC Machines: Some of the smallest TC units may be lifted off of their wooden skid and moved manually. However Promax recommends that moving even the smallest of their TC units should not be attempted by one person. The larger TC units should be lifted with the aid of a fork lift or other approved lifting aid. Prior to lifting with a forklift the forks should be adjusted to a width that provides the machine with stable support. The proper lifting point for TC machines is to place the forks so they come in contact with the units rubber feet located on the bottom of the machine.

SC Machines: All SC units should be lifted from their wooden skid and moved to the location where they will be used with an approved fork lift. Be sure to take note of the points listed below.

DC Machines: All DC units should be lifted from their wooden skid and moved to the location where they will be used with an approved fork lift. Be sure to take note of the points listed below.

*** Make sure the fork lift forks are properly adjusted for width and use fork extensions if needed.**

*** Make sure to ascertain the center of gravity and use identified lifting points.**

2.3 DC-640H SPECIFICATION

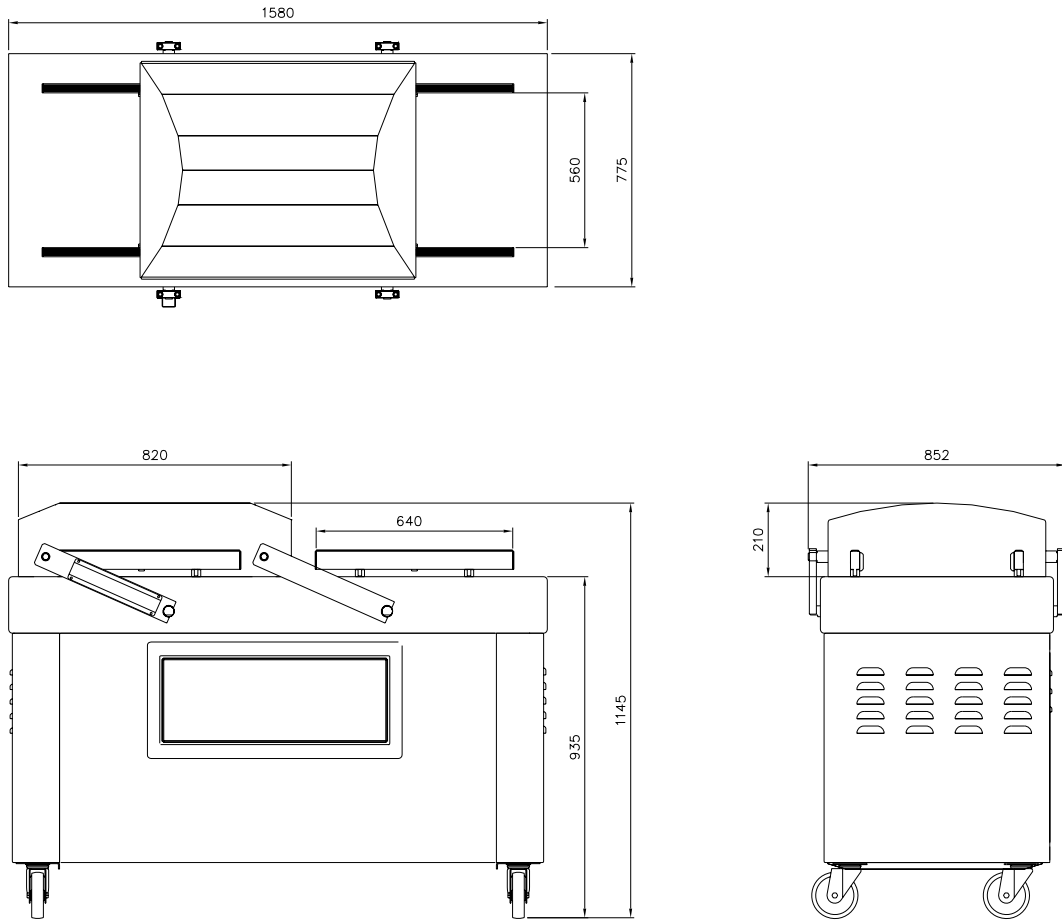

2.4 ENVIRONMENT EQUIREMENTS

The machine will be difficult to start if the air temperature is very low. This is caused by the increase in the vacuum pump's oil viscosity due to the low temperature. To prevent this, please set up machine according to the installation checklist described as below:

- Temperature: around 5 ~ 40°C
- Working elevation: between 0 ~ 1000 meters
- Relative humidity: 30 ~ 95% RH
- During operating, heat is generated by the vacuum pump and vacuum process, so a machine temperature of around 70 ~ 80°C is normal. The machine must have free air access for cooling.
- A minimum distance from walls, other machines, etc. should be maintained, at least 20 cm for each side of machine for providing adequate ventilation.

2.5 CHECK OIL LEVEL

Check the oil level only when the machine is not in operation and all vacuum built up in the chamber has been vented. Be aware that the oil may be very hot and avoid all contact.

Checking the Oil Level

- * Check the oil level on a daily basis
- * When checking the oil level use the sight gauge shown in **figure 1 below**. The level should be between the arrows indicating Minimum and Maximum. If the level is below the minimum arrow add oil until the maximum arrow is reached.

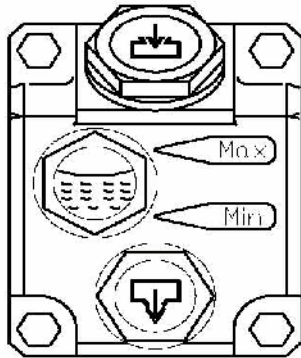

Figure 1

2.6 POWER CONNECTION

When preparing to install the machine's main power connection please refer to the electrical information on the serial number plate located on the machine's back panel. A certified electrician should be employed to complete this connection.

2.7 VACUUM PUMP ROTATION

If your machine operates on 3 phase power it is important to check the rotation of the vacuum pump. The pump should turn in the direction indicated in **Figure 2** below. If the pump turns in the wrong direction it will make a sound that is obviously wrong. Turn off the power immediately and change the position of two of the power wires and retest.

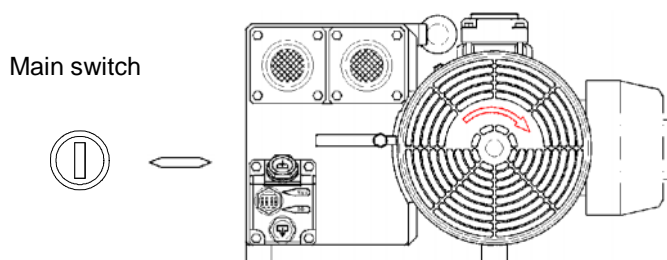

Figure 2

3. OPERATION

3.1 VACUUM SETTING GUIDLINES

Products	Vacuum time/Sec.	Storage life when stored at 2 ~ 6 °C/day
Fresh meat	30	10
Pork	30	10
Beef	30	30
Meat with liquid	15 ~ 30	14
Pasta	3 ~ 9	21
Sliced sausage	15	10
Cold cuts	9	10 ~ 21

3.2 BASIC OPERATING INSTRUCTIONS

Turn on the main switch and the LED display shows the operation menu, at this time, machine is ready to operate.

Place the product to be packaged in a vacuum pouch. Place the bag in chamber with the open end of bag across the sealing bar. (With a package that doesn't completely fill the chamber, place provided flat plates in the chamber to shorten vacuum time.)

Close the lid to start the cycle, the lid will open automatically when cycle is completed.

Take out the sealed product from vacuum chamber. You are ready to start the next cycle.

After all packaging is completed, please let the vacuum pump run for about 15 minutes, then turn off the main switch to shut down the machine.

3.3 OPTIONAL DEVICE

3.3.1 GAS FLUSHING UNIT

If your machine is equipped with an optional gas flush system please note the following points.

Make sure you have connected a regulated gas source to the gas inlet fitting

Do not set your regulator for a pressure of greater than 40psi

Place the open end of your package in front of the gas inlet nozzles

Do not tuck the bag under the gas nozzles

3.4 OPERATION OF THE PNC-01 DIGITAL CONTROL PANEL

3.4.1 Operation of the Model PNC-01 Digital Control Panel

When following the instructions for programming your machine please refer to Fig.5 below.

Figure 5

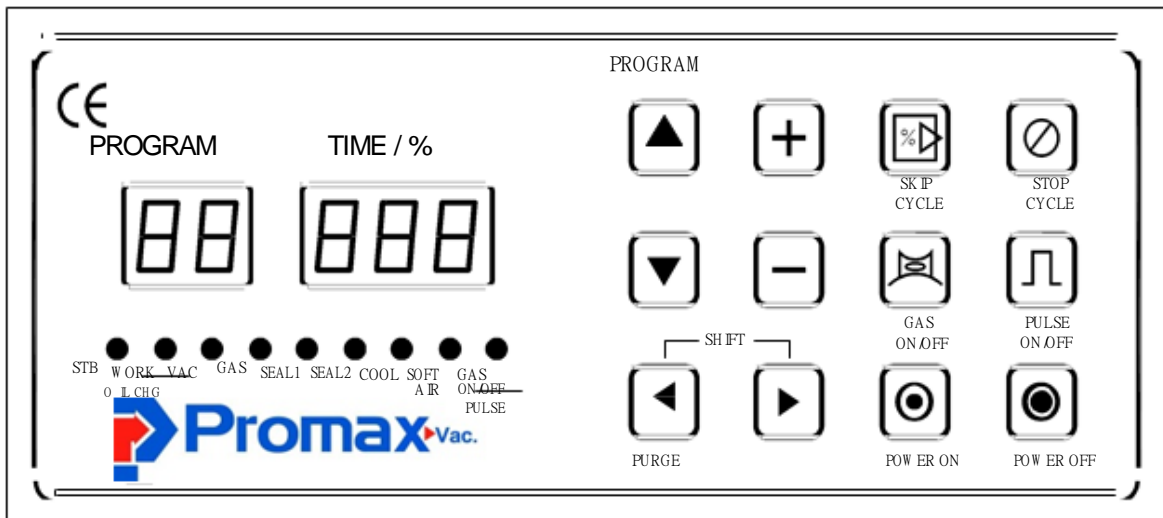

Standard Machine – Basic Instructions

- A. Press the **Main Power** switch located to the right of the control panel.
 1. The Main Power switch will **NOT** light up.
 2. The standby, **STB**, LED on the control panel will light up.
- B. Press the **Power ON** touch pad on the control panel.
 1. The **Program** display and the **Time/%** display will light up.
 2. The **Program** display will indicate what program the machine is running.
 3. The **Time/%** display will indicate the vacuum setting for that program.
- C. **Changing to a different program**
 1. Press either the **Up or the Down** arrow key on the control panel.
 2. You will see the number displayed in the **Program** display change.
 3. Select the program number before the one you want to move to
 4. Press the **Up** arrow key and hold it down for approximately 5 seconds.
 5. You will see the number in the **Program Display** begin to blink.
 6. Press the **Up** arrow key once and it will stop blinking.
 7. Using the **Up / Down** arrows go back to the program number you chose.
 8. **Important:** Cycle the machine 1 time to save program change.

D. Changing Program Settings

1. Choose the program number you wish to edit
2. Press and hold down the **Right Arrow** key for 3 seconds.
3. You will see the **Time / %** display begins to flash.
4. **Change the settings as indicated in steps E to J.**

Important Note: If your machine is equipped with the most recent version of the PNC-01 control you will not need to implement the instructions above in order to change program settings.

E. Vacuum

1. Make sure the **LED** above the word **VAC** is lighted.
2. Using the **Plus/Minus** keys increase or decrease the vacuum time.
3. Press the **Right Arrow** key to move to the next setting.

Important note: You may always use the left arrow key to go back to the previous setting.

F. Gas (Optional) See Optional Settings

1. Using the **Plus/Minus** keys set to 0.00
2. Press the **Right Arrow** key **3X** to move to the next setting.

G. Seal 1

1. Using the **Plus/Minus** keys increase or decrease the seal time.
2. Press the **Right Arrow** key to move to the next setting.
3. Maximum sealing time : 3 seconds.

H. Seal 2: Not used at this time.

I. Cool

1. Using the **Plus/Minus** keys increase or decrease the cooling time.
2. Press the **Right Arrow** key to move to the next setting.
3. Minimum cooling time : 3 -5 seconds.

J. Soft Air: This feature allows the chamber to partially vent in short pulses. Three separate settings are required to complete this operation.

1. The first setting is **Total Vent Time**. Using the **Plus/Minus** keys to set the amount of **Total Vent Time** you want.
2. Press the **Right Arrow** key to move to the next setting. You will see that the soft air LED remains on. However you are now setting the **Vent On time**.
3. Using the **Plus/Minus** keys set the amount of time you want the vent valve to open during each pulse.

Press the **Right Arrow** key to move to the next setting. The Soft Air LED will remain on. However you are now setting the **Vent Off time**.

4. Using the **Plus/Minus** keys set the amount of time you want the vent valve to remain closed between each vent pulse.

5. Press the **Up Arrow** key to return to normal operation mode.

3.4.2 Setting the Parameters for the Optional Settings

Important Note: These settings will only function if the options they pertain to were purchased.

Refer to figure 6 below to help you complete these settings.

Figure 6

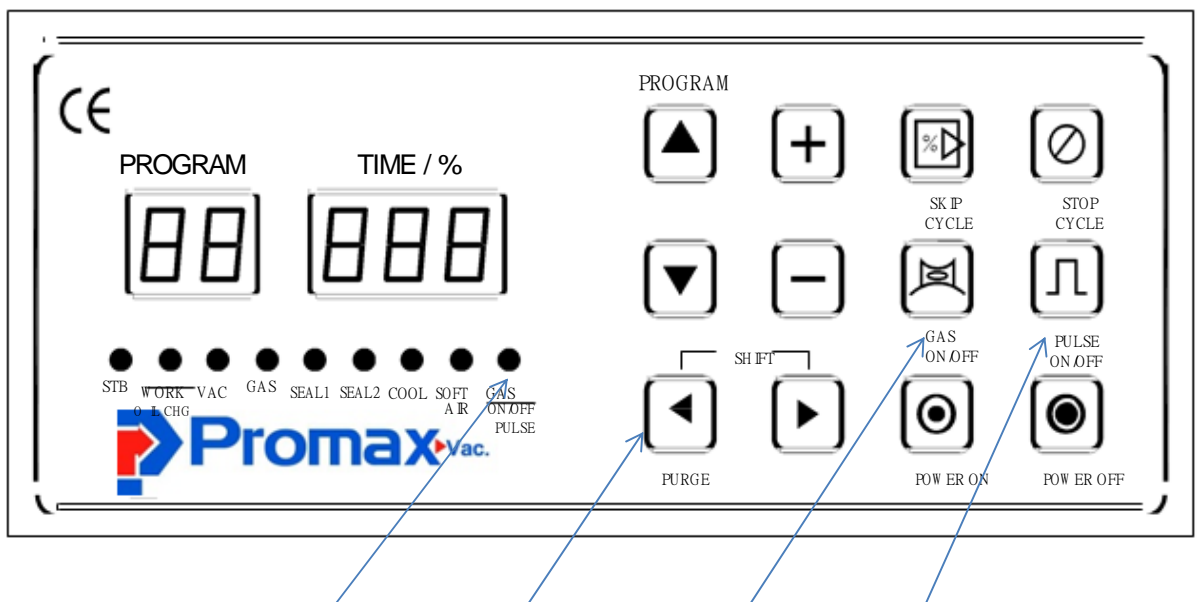

Gas On / Off / Pulse LED

Purge

Gas On / Off Pulse On / Off

A. Gas Flush

1. Prepare to make changes as instructed in point D
2. Press the **Left Arrow** key until the **Gas LED** is lit.
3. Using the **Plus / Minus** keys set the amount of time you want gas to enter the chamber.

4. Press the **Left Arrow** key again you will see that the **Gas LED** remains lit. You will set a time value for the next two settings **only if you wish to use the PULSE GAS feature.**
5. Using the **Plus / Minus** keys set a **GAS ON** time
6. Press the **Left Arrow** key to move to the **GAS OFF** time setting.
7. Using the **Plus / Minus** keys set a **Gas Off** time.
8. Press the **Left Arrow** key to move to the next setting.

Important Note: Once you have returned the control to the normal operation mode you **MUST** turn the GAS Feature and the PULSE feature on for them to become part of the cycle. To do this Press the **Gas On / Off** key, indicated in **Figure 6** above. The **Gas On / Off / Pulse LED** will light up. This indicates that the gas flush system is engaged.

If you wish to engage the **PULSE** feature you must Press the **PULSE On/Off** touchpad indicated in **Figure 6** (on the previous page). The **Gas On / Off LED** will begin to blink. The gas pulse feature is now engaged.

B. Vacuum by Percentage: This option allows your machine to control the amount of vacuum achieved as a function of vacuum pressure instead of being time based. **Your machine must be equipped with the optional Sensor Control for this option to be used.**

1. Enter the Edit Mode (follow the instructions in point D on Pg.00)
2. Make sure the LED above the word VAC is on.
3. Press the **Minus** key repeatedly until you pass **-1**. You will see the Time / Percent display change to **99**.
4. Continue to Press the **Minus** key until you have reached the vacuum percentage you desire..
5. Press the **Left Arrow** key to move to the next setting.

C. Percentage + Time Vacuum: This setting will allow your machine to reach 99% then continue to vacuum for a set amount of time before moving to the next stage of the cycle.

1. Follow the instructions above to the point where the number 99 has appeared in the Time / Percent display.
2. Press the **Plus** key and you will see a 1 with what looks like a sideways T next to it appear.
3. Continue to Press the **Plus** key until you have set the amount of time you want the vacuum to continue after 99% has been achieved.
4. Press the **Left** arrow key to move to the next setting.

D. Pulse Vacuum: This feature allows you to set the vacuum to pulse on and off for a preset **Total Vacuum Time**. If this optional feature has been purchased you will notice that the VAC setting will require three (3) settings to complete.

1. The first setting will be **Total Vacuum Time**. Using the **Plus/Minus** keys set the total time you want the vacuum cycle to last.
2. Press the **Right Arrow** key to move to the next setting. The VAC LED will remain on. However you are now setting the **Vacuum On Time**.
3. Using the **Plus/Minus** keys set the amount of time you want each vacuum pulse to last.
4. Press the **Right Arrow** key to move to the next setting.
5. Using the **Plus/Minus** keys set the amount of time you want the vacuum to remain off between each vacuum pulse.
6. You have now completed setting for a Pulsed Vacuum.
7. Press the **Right Arrow** key to move to your next setting.

E. Multi Stage Vacuum / Gas: This function allows your machine to perform multiple vacuum and gas stages before moving onto the seal mode. Up to 10 vacuum / gas or gas / vacuum stages may be set.

1. With the machine in the normal operation mode Press the Purge key indicated in Figure 6. You will see a decimal point appear in the **Program Display**. The machine can now be set for multi-stage operations that begin with a Vacuum cycle. If you Press the Purge key once more the decimal point will begin to blink. The machine will now perform multi-stage functions beginning with Gas. **Note: The vacuum will engage for 2 seconds to hold the lid down before the first gas stage begins.**
2. Once you have engaged the Purge function then enter EDIT MODE (follow the instructions indicated in point D on page 00).
3. The **VAC LED** will be lit and you will see a number appear in the **Time / Percentage** display. This number indicates how many stages you wish to execute.
4. Press the Plus / Minus keys to set the number of stages you want.
5. Press the **Left Arrow** key. You will see that the LED above the word **VAC** stays on.
6. Press the Plus / Minus Key to set the amount of Vacuum time for all of the vacuum stages. **This second setting is ALWAYS the vacuum time.**
7. Press the Left arrow key. You will see that the LED above the work **VAC** remains on.
8. Using the Plus / Minus keys set the amount of Gas time for all gas cycles. Note: **This third setting is always the Gas time.**

Note: If you Press the Purge key a third time the decimal point will disappear. The Purge function is now OFF and your regular Vacuum & Gas settings will resume.

4.MAINTENANCE

4.1 Basic Maintenance

The following maintenance procedures should be followed no matter what model Promarks machine you own.

4.1.1 Daily Visual Inspection

Your machine should have the following items inspected daily. If this inspection is performed daily prior to the start of your days production you will find that your machine will always perform consistently, last longer and suffer less down time.

A. Teflon Covers

1. Clean if they have any foreign mater adhering to them
2. Look for any burned spots, cuts or tears. Replace if needed.

B. Vacuum Pump Oil

1. Check the oil level. Fill if below Minimum on the sight gauge. Refer to Fig. 1 on page 6.
2. Replace the oil after 500 hours of operating time.

C. Vacuum Chamber Lid Gasket

1. Check for general wear
2. Check for damage
3. Replace as needed.

D. Pressure Bar Rubber: On TC and some SC machines this is the rubber part found in the lid of your machine that meets with the seal bar when the machine is in operation. In other SC machines and in all DC machines this is the rubber part that is located on the chamber's base that meets with the seal bar when the machine is in operation.

- 1 Check for excessive wear.
2. Check for burnt spots, cuts and tears.
3. Replace as needed.

E. Vacuum Pump Motor Sound

1. Listen for the smooth, normal sound of your vacuum pump.
2. If any abnormal sounds are detected **TURN OFF YOUR MACHINE RIGHT AWAY** and perform a trouble shooting procedure.

4.1.2 Daily cleaning

Important Note: The following daily cleaning points are meant to help keep your machine in proper working order. They are in no way intended to provide the required level of sanitation needed for the packaging of food products. As noted earlier in this manual your company should consult with an expert in the sanitation field to design a robust sanitation routine when packaging food products.

1. Clean the seal bar's Teflon tape very carefully using a rag and a mild organic solvent. **DO NOT** directly wash down this area of the machine.
2. Clean the rubber pad in the seal pressure bar. Once again use a rag and a mild organic solvent. **DO NOT** directly wash down this area of the machine.
3. Wipe down the stainless steel housing using an approved stainless steel cleaner.
4. On machines with clear chamber lids or viewing windows clean them using a mild glass cleaner.
5. If your machine is an SC Series or a DC Series unit open the housing access door and visually check for oil or debris around the vacuum pump area. If you see anything that needs to be cleaned **DO NOT start cleaning until the machine is properly locked out and tagged out.**

4.2 VACUUM PUMP MAINTENANCE

For detailed information concerning maintenance and repair of your machine's vacuum pump please refer to the manufactures operating manual that was packaged with your new machine.

4.3 SEAL BAR MAINTENANCE

A. Replacing the Teflon Cover

1. Remove the seal bars from your machine.
 - a. Seal bars are located in the chamber on all TC Series machines and some smaller SC Series machines.

- b. Seal bars are located in the lid on larger SC Series machines and all DC Series machines.
- 2. Remove the screws that hold the Teflon holding strap in place. Refer to **Figure A on the next page**.
- 3. Remove the old Teflon cover.
- 4. Inspect the seal element.
 - a. Clean it off with lacquer thinner if needed.
 - b. Replace if broken or burnt badly. **Refer to the instructions under B below for replacement**
- 5. Install the new Teflon cover and reinstall the seal bars.

B. Replacing the Seal Element

- 1. Using a hex wrench loosen the screws holding the seal element and remove it
- 2. Install the new seal element. **Refer to Figures B & C on the next page.**
 - a. Place the new element across the surface of the seal bar leave an excess of about 3/4" at each end.
 - b. Make sure you put the tension spring back in place.

4.4 V A C U U M V A L V E M A I N T E N A C E

4.4.1 VENT VALVE GREASING PROCEDURE

- 1. First, remove the inner snap ring.
- 2. Second , you can remove the valve piston.
- 3.Third , put a small amount of grease on the o-ring and reassemble(FIG1).

4.4.2 VACUUM VALVE GREASING PROCEDURE

- 1.First , remove the four hex nuts(FIG2 A).
- 2.Second , apply small amount of grease to o-ring(FIG2 B).
- 3.Next , apply small amount of grease to inside well of piston housing(FIG2 C).
Re-assembly

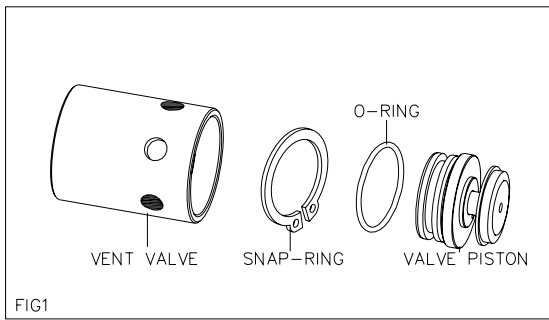

FIG1

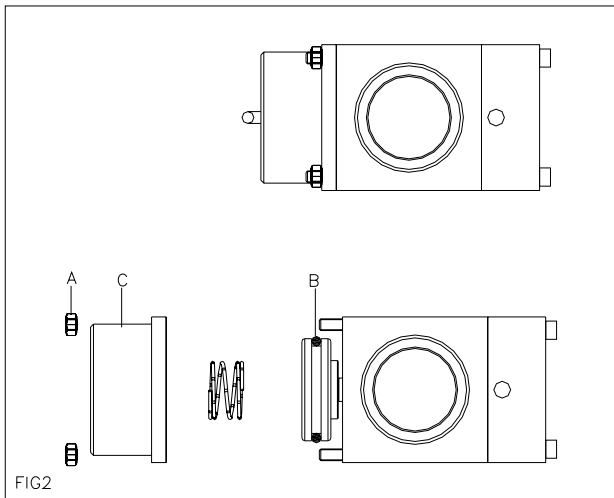

FIG2

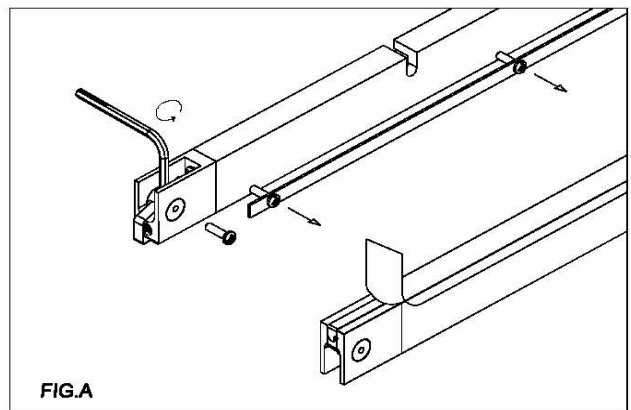

FIG.A

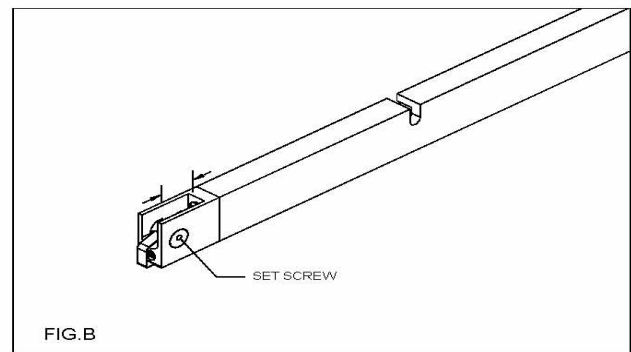

FIG.B

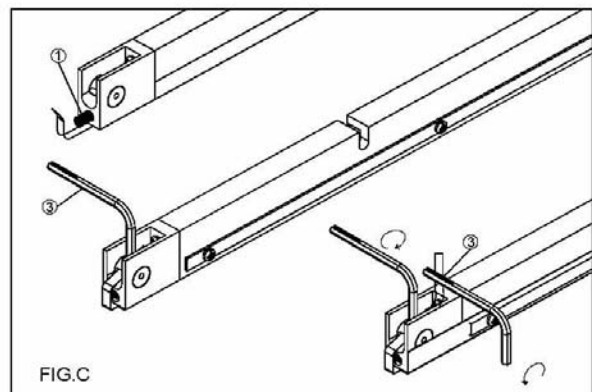

FIG.C

4.5 MAINTENANCE INTERVALS AND CHECK ITEMS

Maintenance Intervals/ Check items	Daily	Bimonthly	Quarterly	Yearly	Biyearly	3 ~ 5 years	Note
Keep the vacuum lid open after finished working and let vacuum pump running about 15 minutes.	X						
Check the oil level	X						
Check the sound of motor	X						
Oil come out from exhaust cover or not	X						
Bottom sealing bar working normally or not	X						
Clean the exhaust filter		X					
Change vacuum oil		X					
Replace exhaust filter				X			
Replace Teflon tape				X			As request
Replace sealing Silicone rubber				X			As request
Replace lid gasket rubber				X			As request
Replace pressure bag					X		As request
Replace vanes						X	

Above-mentioned maintenance intervals are scheduled basically for 8 working hours per day.

Recommended oil : A. Grav. API 30.5
 Pour Pt. -15°C
 Flash Pt. 225°C
 Viscosity 32.05 CST@40°C
 Color Light Yellow
 V.I. 100

5. TROUBLESHOOTING

5.1 PROBLEMS AND CORRECTIONS

Problem and Corrections - Review installation procedure section to ensure the installation is correct. If correct, the troubleshooting chart below lists possible problems, causes, corrections, and reference guide.

Problem	Cause	Correction
Control panel is under normal function, but vacuum pump does not start.	The KM1, QM1, MCB1, MCB2 protectors are disconnected.	Check each part and turn on the switch, reconnect, if necessary.
Vacuum pump does not run.	The power supply is not corresponding with the power demand indicated on the back of machine.	Reconnect to correct power source.
Insufficient vacuum in chamber.	Low oil level in vacuum pump. Lid silicone rubber damaged.	Fill oil, if necessary. Stop machine immediately. Then alter the power connection and reconnect to correct ones. Replace.
Insufficient vacuum in bag. Note : Mostly insufficient vacuum in bag is due to leakage of bag, but not the fault of machine.	Bag is leaking. Sharp corners on wrapped product puncture the bag. Bag is too large.	Replace the bag. Replace the bag and use a thicker one. Replace with a smaller one.
Vacuum bag is easily pulled apart by hand.	Sealing time (temperature) is too short (low).	Adjust sealing time (temperature) to be longer (higher).
Sealing area has some burnt marks or bubbles appeared.	Sealing area stuffed with oil or meat juice or dirt. Sealing time (temperature) is too long (high).	Clean and remove them. Adjust sealing time (temperature) to be shorter (lower).
Chamber Lid does not open.	Vent valve is sticking.	Apply grease refer to 4.4.1.
Machine does not start to vacuum	Vacuum valve is sticking	Apply grease refer to 4.4.2

Problem	Cause	Correction
No or improper sealing.	Sealing wire is broken.	Replace it.
	Sealing wire is loose.	Tighten it.
	Insufficient pressure.	Pressure bar is damaged, replace it.
	Sealing transformer is damaged.	Replace it.
	Teflon tape or silicone rubber is damaged.	Replace it.
	Sealing time and cooling time are too short.	Adjust to proper time.
NOTE : Please do not adjust sealing longer than regular time, or it will reduce the life of Teflon tape and silicone rubber.	Sealing pressure is too low.	Replace the pressure bag.
	Lid does not close.	
	Vacuum valve is damaged.	Replace it.
	Limit switch is disconnected or damaged.	Reconnect or replace it.

5.2 25PIN D Type Terminal Wiring Connection Instructions

PIN NO	FUNCTION		PIN NO	FUNCTION	
1	AC24V Input — For Internal		13	External DC24V	Rectificated
2	AC24V Input — For Internal		14	External DC24V	Rectificated
3	AC24V Input — For External		15	Sealing Bar 2 Heat Contact	Relay Contact
4	AC24V Input — For External		16	Pulse Soft Air Contact	Relay Contact
5	Air Inlet Valve	Relay Contact	17	x	
6	Sealing Press Bar Gas Flushing	Relay Contact	18	x	
7	Sealing Bar 1 Heat	Relay Contact	19	x	
8	External Special Gas Valve	Relay Contact	20	x	
9	Vacuum Valve	Relay Contact	21	Over Relay Input Same As 25	External Input
10	COM	Relay Contact	22	Internal Grounding	External Input
11	Internal Grounding	External Input	23	COM point	Relay Contact
12	Vacuum Lid Signal Input	External Input	24	Vacuum Motor Contact	Relay Contact
			25	Over Relay Input Same As 21	External Input

5.3 PNEUMATIC DIAGRAM

NO	DESCR	QTY	NOTE
1	Vacuum Valve Set	1	
2	Vacuum Pump	1	
3	Ventilation Valve	1	
4	Vacuum Valve	1	
5	Sealing Valve	1	
6	Gas Valve	1	
7	Gas Valve	1	
8	Pressure control valve	1	
9	Vacuum Gauge	1	
10	Control panel	1	

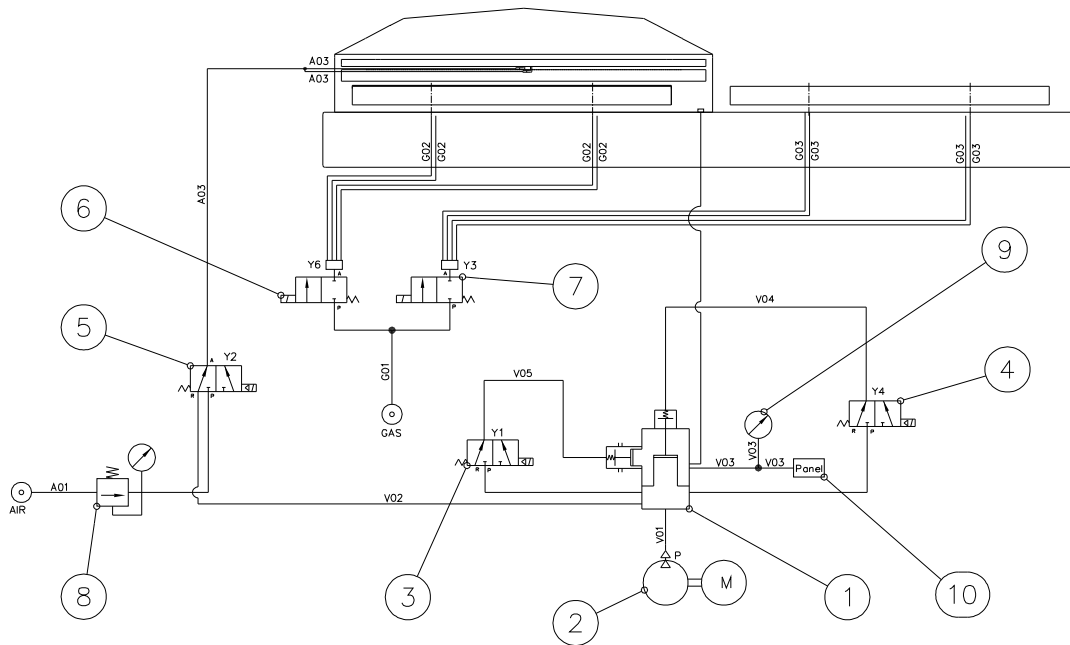

5.4 ELECTRICAL DLIAGRAM(FB)

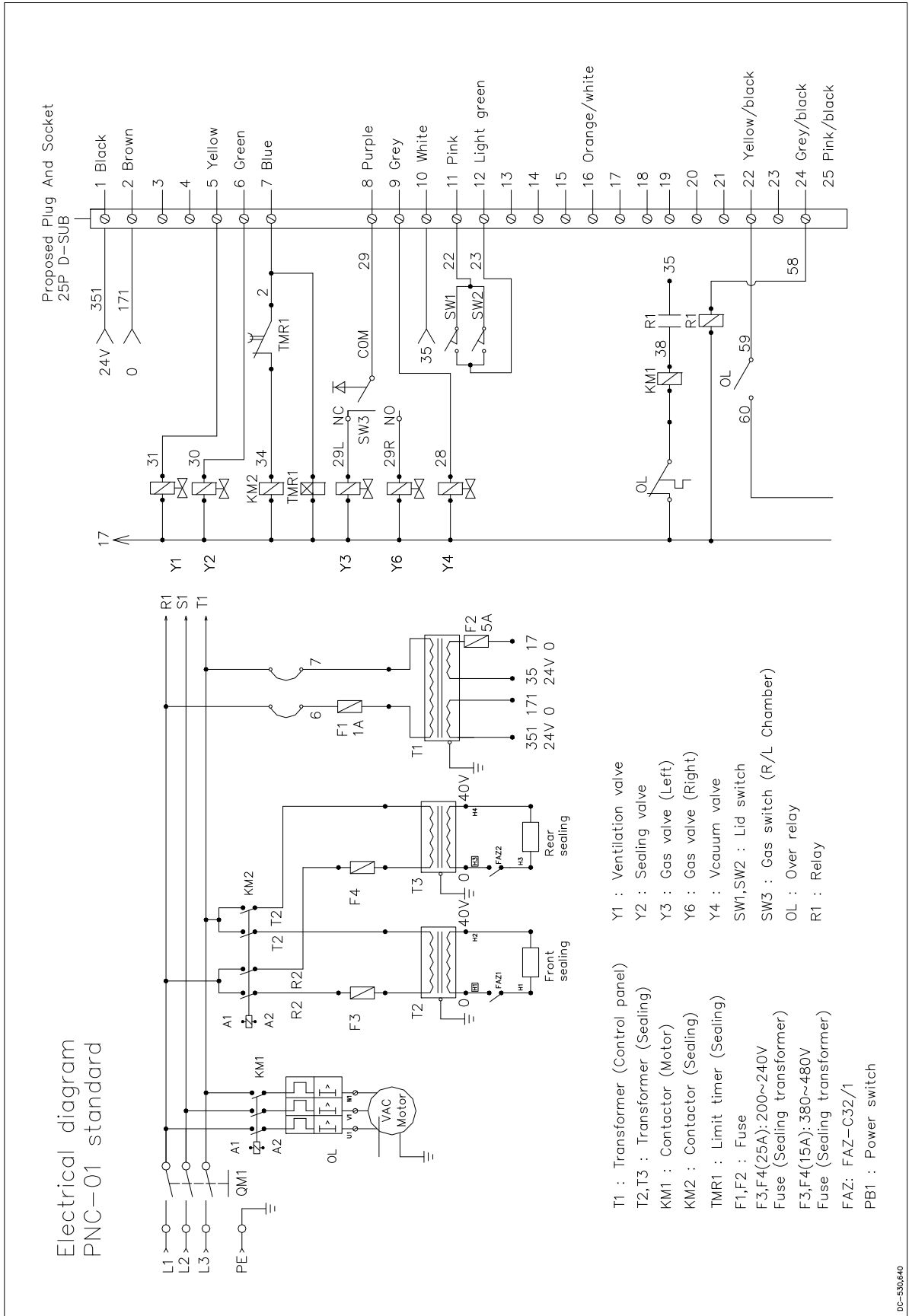

6. FABRICATION

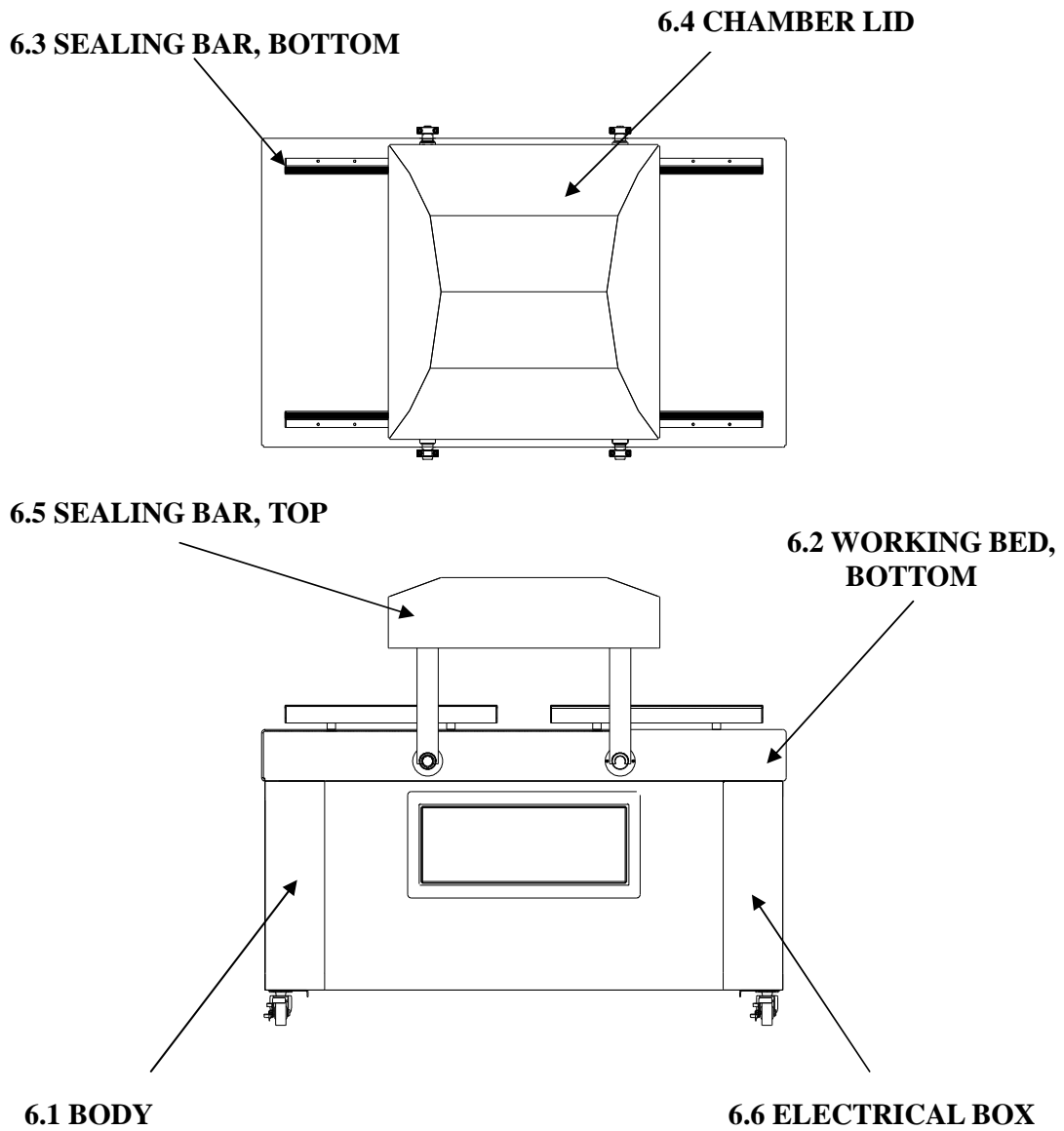

6.1 BODY

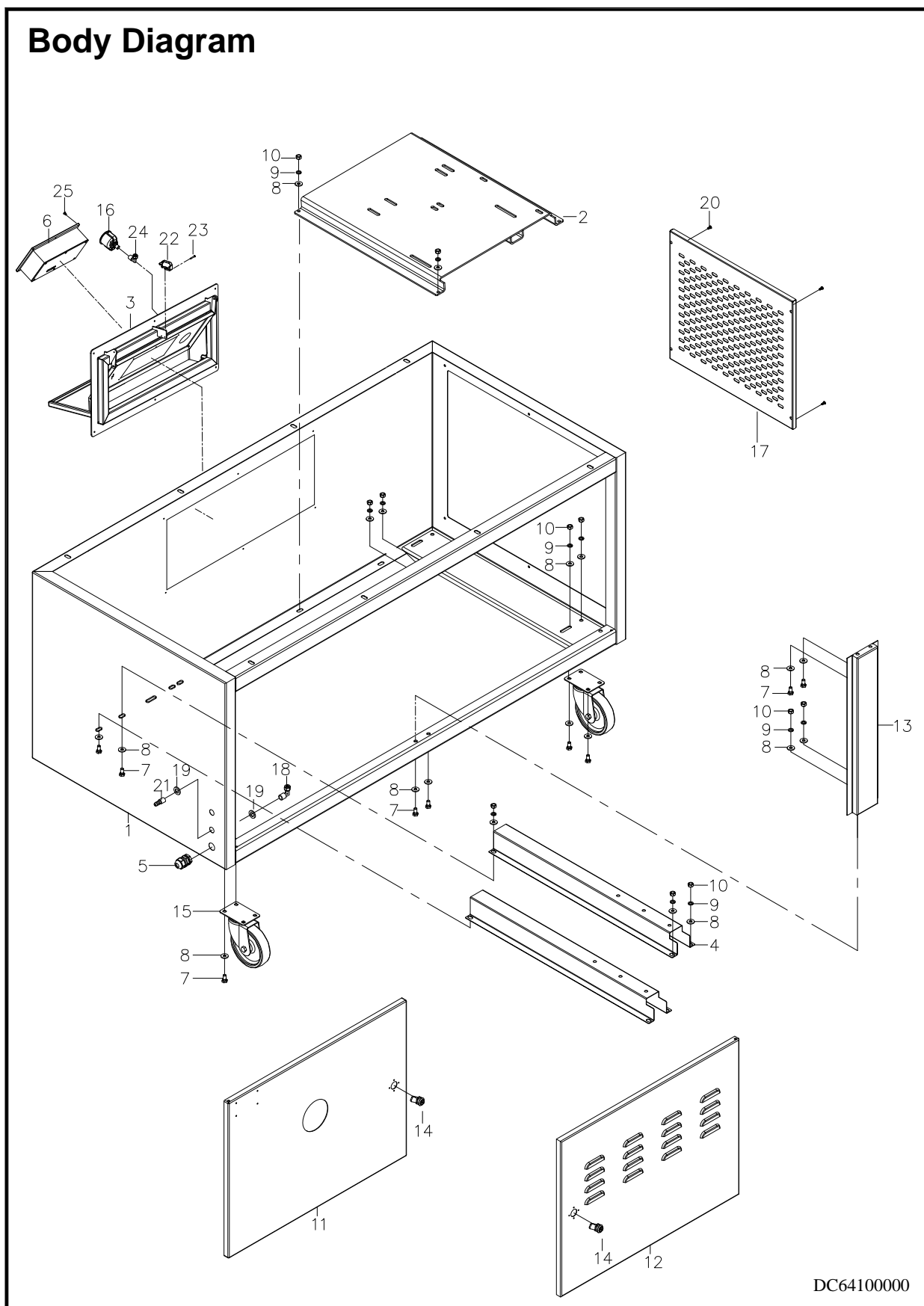

NO.	PART NO.	DESCRIPTION	QTY	NOTE
1	DC64101002	Frame	1	
2	DC64107000	Vacuum pump mounting bracket	1	
3	DC80131001	Front control panel assembly	1	
4	DC64106002	Electrical box mounting bracket	2	
5	2861023	Straight connector MG-32A	1	
6	2874033	Control panel	1	
7	2700408	Hex head screw M8 x 20 (S)	40	
8	2705152	Flat washer M8 (S)	80	
9	2705301	Split lock washer M8 (S)	40	
10	27072032	Nut M8 (S)	40	
11	DC64118002	Back door - R	1	
12	DC64117001	Back door - L	1	
13	DC64102000	Plate	1	
14	2883349	Door lock	2	
15	27121181	Casters	4	
16	29135564	Pressure Gauge 2"x760mm	1	
17	DC64115001	Side door - L	1	
18	29090428	Fitting nylon tube A-028	1	
19	2705155	Washer flat M14	2	
20	2701353A	Hd roun screw M4x12	8	
21	29091755	Fitting nylon tube P-18	1	
22	2883330	Limit H-25	1	
23	27030142	Hd roun screw M3x12	2	
24	29090426	Nylon tube fitting	1	
25	2703307	Round head screw M4x10	6	

6.2 WORKING BED (BOTTOM)

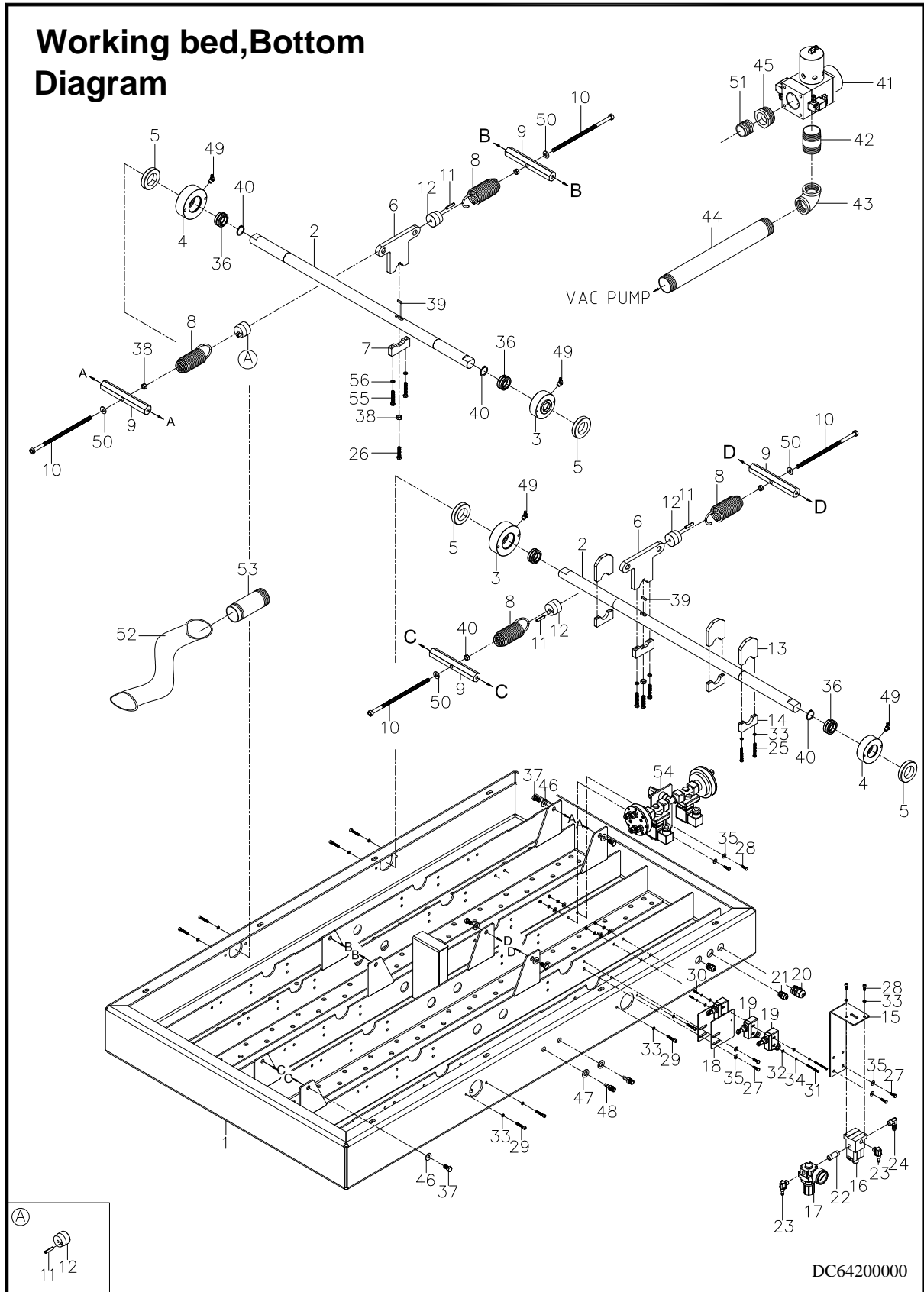

NO.	PART NO.	DESCRIPTION	Q'TY	NOTES
1	DC64201001	Welded body (FB ; PK)	1	
	DC64218000	Welded body (TB;TK)		
2	DC64202001	Main shaft	2	
3	D80K203000	Bearing bracket	2	
4	D80K204000	Bearing bracket	2	
5	D80K205000	Washer	4	
6	D80K206000	Bracket - Spring, Top	2	
7	D80K207000	Bracket -Spring , Bottom	2	
8	DC64208000	tension spring	4	
9	D80K210000	Spring mounting bar	4	
10	DC64211000	Spring adj. screw	4	
11	2708012	Spring pin	4	
12	DC53207000	Spring pull shaft	4	
13	D80K212000	Sensor plate	3	
14	D80K213000	Sensor plate	3	
15	DC80216001	Solenoid valve mounting plate	2	
16	2911805	Solenoid valve VT317-9D-02 AC24V	1	
17	29100056	Air regulator SMC AR20-02H-A	1	
18	DC80215000	Limit switch bracket	2	
19	2853313	Limit switch	3	
20	2861022	Fitting - electric conduit, MG Type MG-25A-18B	1	
21	2861021	Fitting - electric conduit, MG Type MG-20A-14B	2	
22	2909002	Fitting, P-12 1/4"x1/4"	1	
23	29090312	Speed control valve - L type VSL-8x1/4"	2	
24	29093431	Iron fitting 1/4 x 5/16	1	
25	2700403	Hex head screw M6 x 50	6	
26	2700441	Hex head screw M8 x 35	2	
27	27004011	Hex head screw M6 x 20	6	
28	2701152	Hex socket head screw M6 x 16	4	
29	27011551	Hex socket head screw M6 x 35	8	
30	2703311	Round head screw M4 x 30	2	
31	27033161	Round head screw M4 x 60	2	
32	2705306	Split lock washe M4	4	
33	2705302	Split lock washe M6	16	
34	2705154	Split lock washe M4	4	
35	2705151	Split lock washe M6	12	

NO.	PART NO.	DESCRIPTION	Q'TY	NOTES
36	27281156	Bearing GE30ES	4	
37	D80K231001	Hex head screw M10 x 25	8	
38	2707203	Hex nut M8	6	
39	2709206	Key 8 x 8 x 20	2	
40	2706239	Ring R47	4	
41	D80K235000	Vacuum valve assembly 2"	1	
42	290932573	Nipple 2" x 2"	1	
43	2740068	Fitting - pump hose 2"	1	
44	290932572	Nipple 2" x 365mm	1	
45	2909007D	Fitting 2" x 1-1/4" (R5 0100E)	1	
	29090072	Fitting 2" x 1-1/2" (R5 0205D; R5 0305D)		
46	2705189	Flat washer M10	8	
47	2705186	Flat washer 1/2"	2	
48	29091751	Fitting, Nylon Tube 90° B-01 1/4PT x 1/4H	2	
49	27401402	Nipple, Grease 1/8	4	
50	27046153	Washer flat M8	4	
51	2909325632	Nipple 1-1/4" x 40mm (R5 0100E)	1	
	2909325631	Nipple 1-1/2" x 40mm (R5 0205D; R5 0305D)		
52	274000671	Fitting - pump hose 1-1/4 (R5 0100E)	1	
	27400067	Fitting - pump hose 1-1/2 (R5 0205D; R5 0305D)		
53	DC80150000	Pump air wire fitting (R5 0100E)	1	
	DC80140000	Pump air wire fitting (R5 0205D; R5 0305D)		
54	DC804G0000	Gas nozzle electrical unit	1	OPTION
55	27004202	Hex head screw M8 x 50	4	
56	2705301	Split lock washer M8	4	
A	DC53207A00	Spring pull shaft assembly	4	

6.3.1 CUSHION BAR (FB)

Cushion Bar Diagram

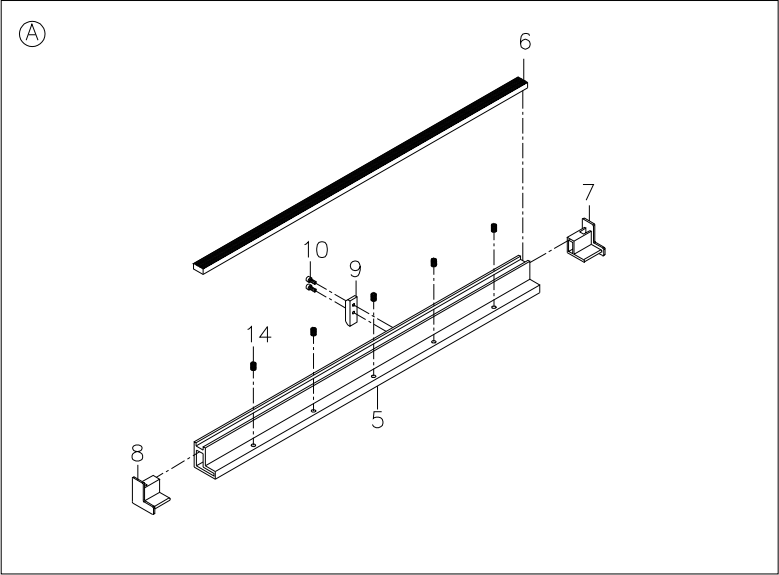
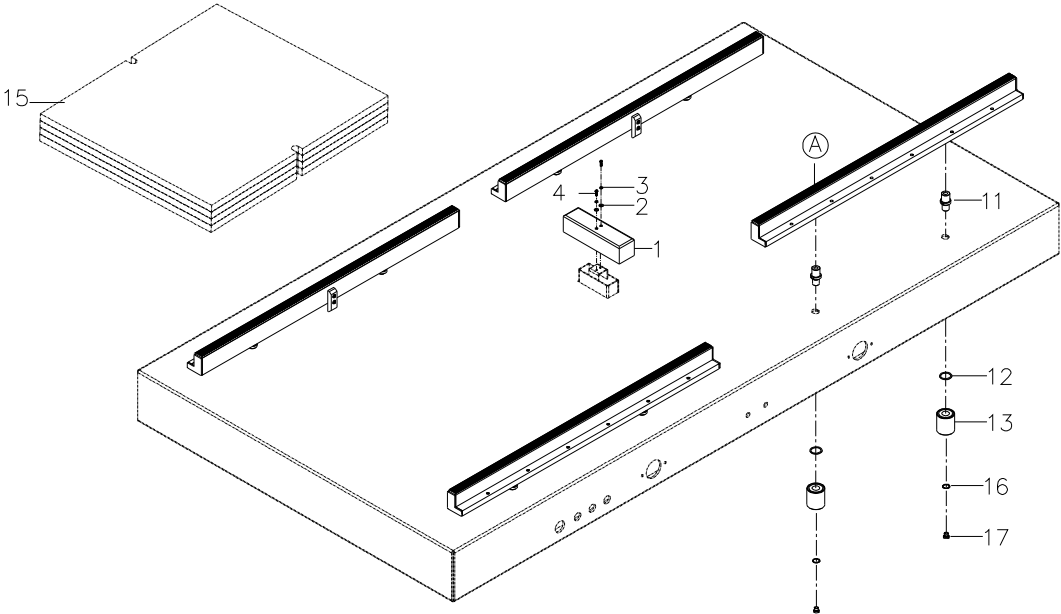

DC642FB000

NO.	PART NO.	DESCRIPTION	QTY	NOTE
1	DC80202000	Cover - vacuum suction	1	
2	2705154	Flat washer M4	2	
3	2705306	Split lock washer, M4	2	
4	2703308	Round head screw M4 x 12	2	
5	DC64223000	Sealing bar - bottom (FB)	4	
6	3114462	Sealing silicon	4	
7	D80K226000	Silicon bar end insert-L	4	
8	D80K225000	Silicon bar end insert-R	4	
9	D80K224000	Inner plate	4	
10	2701164	Socket set screw M4 x 10	8	
11	DC8021000	Support shaft - bottom sealing bar	8	
12	2740168	O-ring	8	
13	DC80211000	Nut - bottom sealing bar support shaft	8	
14	2867290	Cap	5	
15	DC64222000	Flat plate	4	
16	2740171	O-ring	8	
17	DC80212000	Cap	8	
A	DC642FB000	Cushion bar assembly	4	

6.4 CHAMBER LID DIAGRAM

Chamber Lid, top Diagram

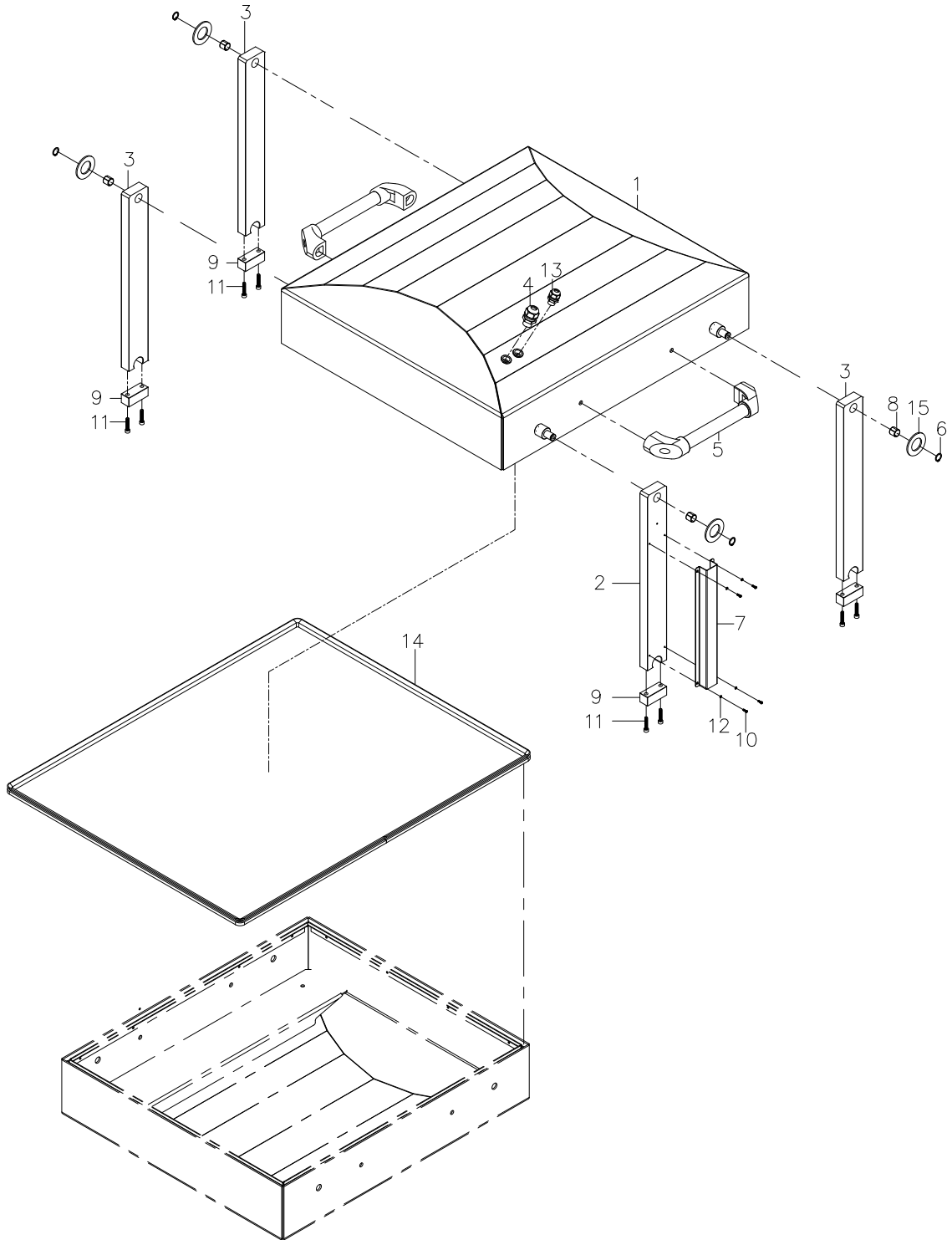

DC64300000

6.5.1 SEALING BAR, TOP (FB)

Sealing Bar-Top Diagram

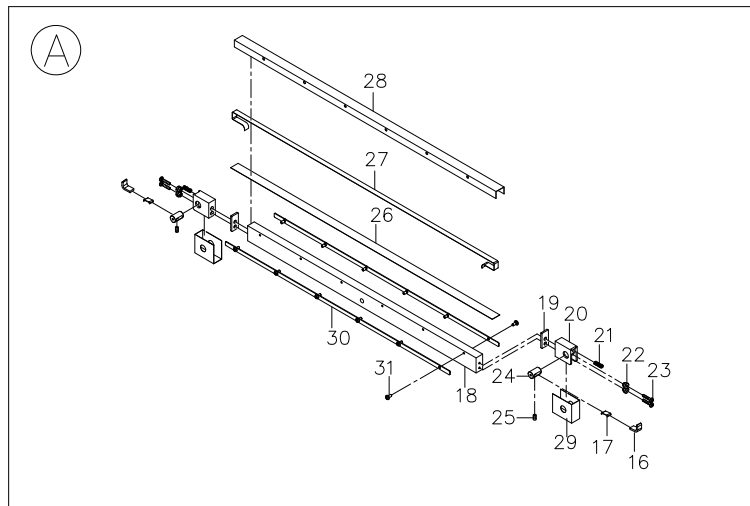
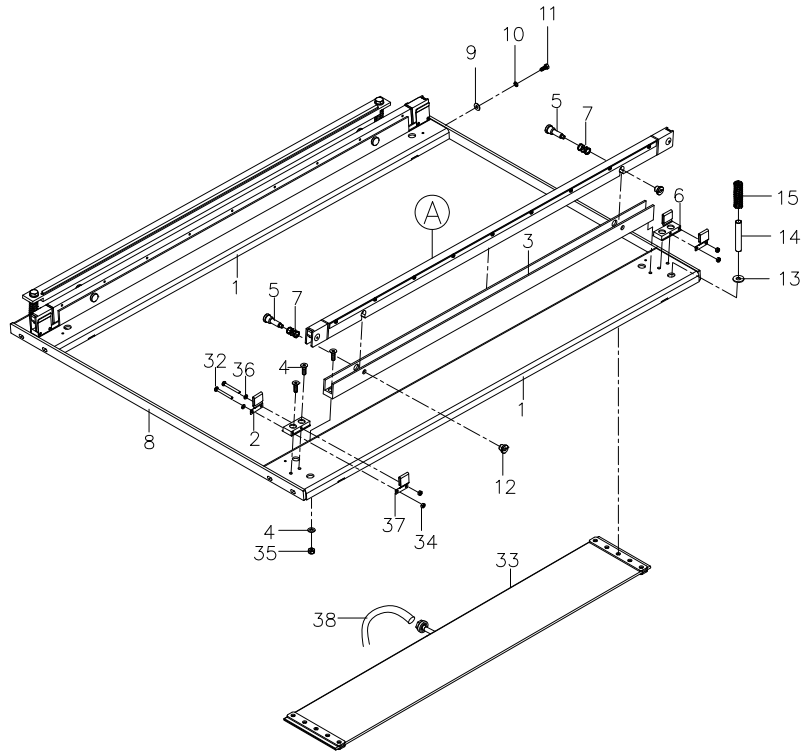

DC64312A01

NO.	PART NO.	DESCRIPTION	QTY	NOTE
1	DC64302002	Holder - sealing bar (F)	2	
2	D80K343000	Electrode plate	4	
3	DC64311001	Holder - sealing bar	2	
4	2702082	Flat head screw M6x12	4	
5	D80K340000	Fixed shaft	4	
6	D80K341000	Fixed mount	4	
7	B80K321000	Spring	4	
8	DC64307000	Jointer - sealing bar	2	
9	2705150	Flat washer M5	8	
10	2705303	Split lock washer M5	8	
11	2700414	Hex head screw M5x12	8	
12	B80K320000	Fixed bushing	4	
13	2705304	Flat washerM10	4	
14	D80K308000	Bushing	4	
15	D80K309001	Compression spring	4	
16	D80K375000	Spring fixed plate	4	
17	D80K377000	Lining plate	4	
18	DC64312001	Sealing bar - top	2	
19	D80K314000	Isolated flat plate	4	
20	D80K315001	Copper connector - sealing	4	
21	VA04277000	Compression spring	4	
22	D80K317000	Isolated sleeve	8	
23	2703327	Round head screw M4x20	8	
24	D80K316001	Connecting copper shaft	4	
25	2704603	Socket set screw M6x10	4	
26	S022102	Teflon tape	2	
27	282411115	Sealing wire	2	
28	3200953-3	Teflon tape	2	
29	3200955	Teflon tape	4	
30	DC64313000	Teflon tape plate	4	
31	2703325	Round head screw M4x8	36	
32	2703310	Round head screw M4x30	16	
33	DC64304A00	Pressure bag assembly	2	
34	2707210	Hex nut M4	16	
35	2707110	Hex nylock nut M6	4	

6.6 ELECTRICAL BOX(FB)

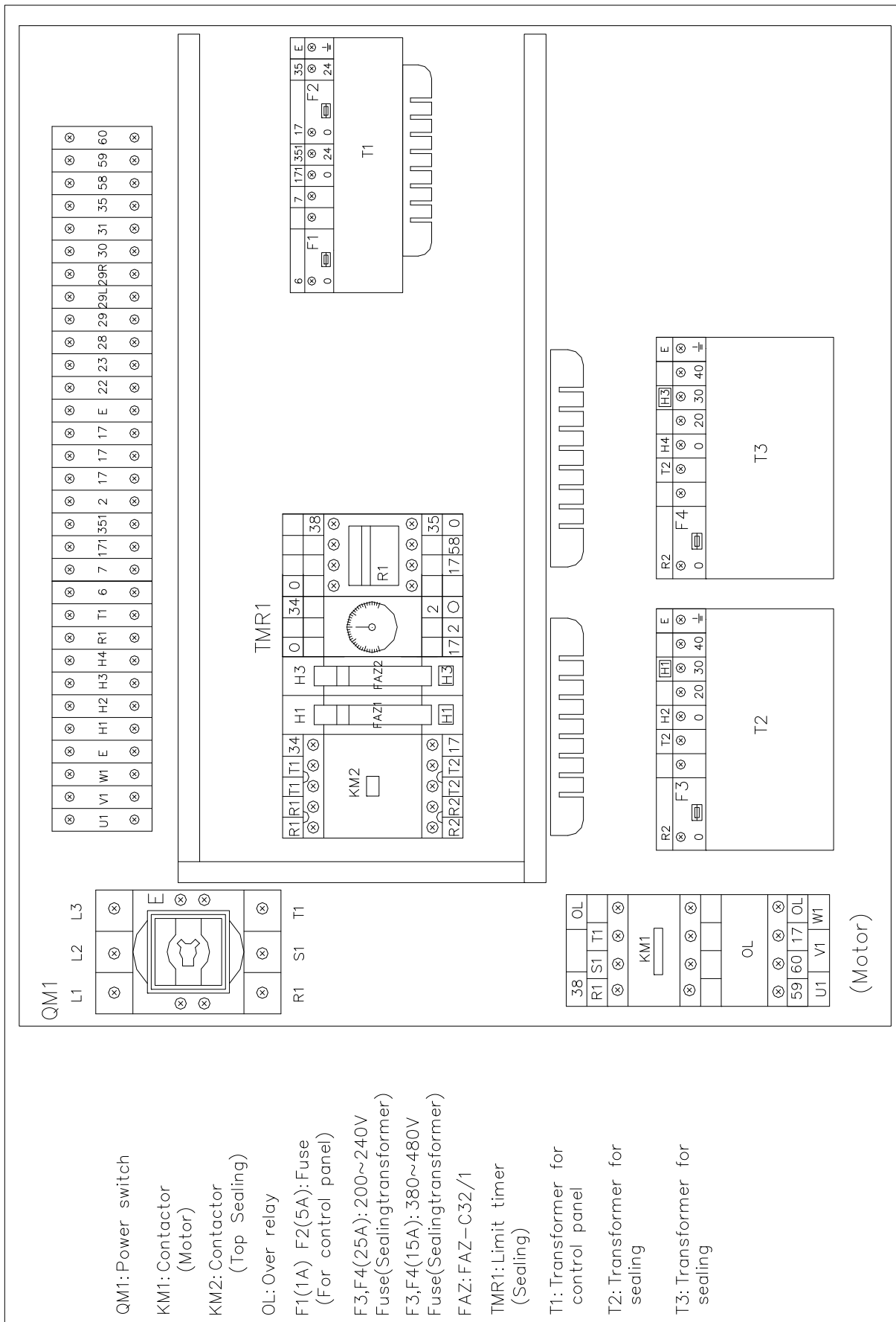

ITEM	PART NO.	DESCRIPTION	SPECIFICATION	Q'TY	NOTE
KM1	2810745	Contactora	CU-18-B5 (AC24V/3A1a)	1	
KM2	2810755	Contactora	DILMP20 (AC24V/4A)	1	
OL	2811537	Overload Relay	RHU-10K1(9~12.5A)	1	3 ϕ 220V/63PUMP
	2811538		RHU-10K1(11.3~16A)	1	3 ϕ 220V/100PUMP
	2811535		RHU-10K1(5.5~7.5A)	1	3 ϕ 220V/40PUMP
R1	2830132	Relay	RU4S-C-A24	1	
	2831106	Socket, Relay	SY4S-05D	1	
	2850636	Hook	PYC-A1	2	
F1	2890048	Fuse	20mm 1A	1	
F2	2890046	Fuse	20mm 5A	1	
F3~F4	2890068	Fuse (FB)	20mm 15A(380~480V)	2	Option
	2890069		20mm 25A(200~240V)		
F3~F5	2890068	Fuse (TB)	20mm 15A(380~480V)	3	Option
	2890069		20mm 25A(200~240V)		
QM1	2807121	Switch, Selector	P1-32/V/SVB-SW	1	
	28071211	Link Bracket	MOELLER ZVV-TO	4	
	28071212	Link-Selector SW	MOELLER ZAV-TO	4	
FAZ1~2	2801734	Breaker	FAZ-C32/1	2	
FAZ1~3				3	TB
TMR1	2833328	Time Relay	ANLY AMY-2 6S AC24V	1	
	2833329	Socket Relay	PYF08A-E MY2	1	
	2850635	Hook	FM-4	2	
T1	28960020	Transformer TBSW-1I-120VA	OF-200-220V/0-24, OF-24 UL	1	Option
	28960022		OF-380-415V/0-24, OF-24 UL		
	28960023		OF-400-440V/0-24V, OF-24 UL		

ITEM	PART NO.	DESCRIPTION	SPECIFICATION	Q'TY	NOTE
T2~T3(FB)	28960045	Transformer 500VA	OF-200-220V/0-20- 30-40 UL	2	3φ 220V
T2~T3(TB)	28960045	Transformer 500VA	OF-200-220V/0-20- 30-40 UL	3	
T2~T3(FB)	28960048	Transformer 500VA	OF-400-480V/0-20- 30-40 UL	2	3φ 400V
T.B	2843212	Terminal Block	PTU-10	24	
	2843209	Terminal Block	PTU-30	4	
	2843213	Terminal Block	PTU-80	4	Option
	2843210	Plate, Terminal Block	PTU-30L2	1	
	28432131	Plate, Terminal Block	PTU-80L	1	Option
	2843207	Brake, Terminal Block	SBN-20(TA-002)	2	
BOX	DC64800000	Electrical Box		1	
WIRE	DC65808000	heating element		1.set	FB
	DC65808T00	heating element		1.set	TB