



**SS-50P/100P**

**FLOOR MODEL STAINLESS**

**HYDRAULIC PISTON STUFFER**

**Operation Manual**

Version 6.9.1

1915 E. Acacia Street, Ontario, CA91761, U.S.A

TEL : 1-909-923-3888

FAX : 1-909-923-3588

<http://www.promarksvac.com>

S/N:

\_\_\_\_\_

QC SIGNATURE:

\_\_\_\_\_

# TABLE OF CONTENTS

<b>1. SAFETY .....</b>	<b>1</b>
<b>2. STARTUP .....</b>	<b>3</b>
<b>3. OPERATION.....</b>	<b>4</b>
<b>4. MAINTENANCE.....</b>	<b>6</b>
<b>5. ELECTRICAL DIAGRAM .....</b>	<b>7</b>
<b>6. PARTS .....</b>	<b>8</b>
<b>7. ELECTRICAL BOX.....</b>	<b>12</b>

# General

This owner's manual contains information relating to your Promax machine. It will provide you with basic information concerning both operation and maintenance of your new machine. Please read it carefully as failure to do so may result in bodily injury and / or damage to the equipment.

Please fill in the information below. You will find the information on the bill of lading and on the machines identification tag. You will need this information when ordering replacement parts or making technical inquiries.

Model # \_\_\_\_\_

Serial # \_\_\_\_\_

Ship Date: \_\_\_\_\_

Owner: \_\_\_\_\_

Location: \_\_\_\_\_

# 1. SAFETY

## Personal Safety

The procedures and guidelines herein must be followed precisely to avoid problems that can result in property damage, personal injury, or death. If you have any questions related to this information, please contact Promax/Promarks Services Inc. at (909) 923-3888.  
**DANGER** Hazardous voltage.

Disconnect and lockout power before servicing machine or cleaning. Do not open control panel unless power has been disconnected, locked out, and tagged out at risk of electric shock hazard.

### WARNING

Read and understand owner's manual before using this machine. Failure to follow operating instructions could result in personal injury or damage to equipment.

### WARNING

Moving parts. Pinch point hazard.  
Do not put hands into machine while running. Ensure that the equipment is not operating prior to freeing product or handling equipment.

Signal words used in classification of potential hazards are defined as follows:

**DANGER:** Indicates an imminently hazardous situation, which, if not avoided, may result in death or serious injury.

**WARNING:** Indicates a potentially hazardous situation, which, if not avoided, could result in death or serious injury.

**CAUTION:** Indicates a potentially hazardous situation, which, if not avoided, may result in minor or moderate injury. Caution also indicates actions that may cause property damage.

# General Safety Guidelines

## **Obvious safety guidelines should be observed.**

Place machine on a flat, stable surface.

Only specialized and expert operators authorized by the manufacturer should carry out all routine and unexpected maintenance operations of the machine.

These operating instructions form an integral part of the machine and must accompany the piston stuffer for its entire lifetime until demolition.

Never remove or change the protection and safety devices, especially those installed at the meat inlet.

Do not touch the moving device if the machine is not completely stopped.

Never go near the machine with loose hair, clothes, bracelets, chains, rings, ties, etc. to avoid the chance that they may become tangled in the moving parts of the machine. As a consequence, the operator shall wear suitable clothes for the working environment and the situation he/she is in.

The manufacturer cannot take any responsibility for modifications made to the original piston stuffer other than those mentioned in these operating instructions.

Be sure to turn off power to your piston stuffer before any maintenance work is performed.

Never reach into or put anything into the ventilation slots of the machine.

Care should be taken when there is a need to remove any of the internal, overhead panels.

The best safety precaution around any machine is to keep it clean! Always keep a fire extinguisher (Type BC) close to the machine.

# 2.STARTUP

## Installation

Unpack the piston stuffer carefully and check the shipment label. After the stuffer is unpacked, please read the instructions carefully and take the following precautions:

1. Ensure the person installing the piston stuffer is a qualified OEM service technician.
2. Check for the correct power source the machine will be plugged into.
3. Check all the components of the piston stuffer to ensure that they are correctly installed and that they have not shifted in transportation.

## Power Requirements

The piston stuffer must be plugged into a grounding outlet. If for any reason no grounding outlet is available, a 10A differential switch with a maximum sensitivity of 15mA should be installed. The feed line in a fixed conduit must be a 750 VAT wire with a double insulation layer. If the piston stuffer is plugged to a wire not fixed in a conduit, the wire must be of 1000 VAC.

Before switching on the machine, make sure that it is correctly installed and that the safety devices are attached to the machine. Carry out overload tests and wire insulation tests to guarantee minimum causes of direct or indirect contact.

Before connecting the machine to the mains, please make sure that the electric system conforms to the features set out on the data plate. If not, perform the following:

1. Change connections in motor terminal box, as indicated in Fig. 1.
2. Change the contact.

Fig. 1

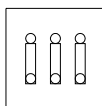

220V

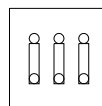

110V

Take into account that the piston stuffer motor operates only on one voltage and cannot be changed. If the piston stuffer voltage needs to be changed, please contact our technical service staff, as a great deal of specialized, hard work is required.

If the above-mentioned verifications are not applied, the piston stuffer motor and

electric components can suffer serious damage. Promax/Promarks Equipment LLC will not accept any responsibility for damages that the machine may suffer by not observing the precautions outlined.

## Startup

1. Before starting the machine for the first time, fill the oil tank.
  - FILLING OIL TANK: Remove the machine side cover, take off the filler cap, and fill the oil tank with one of the recommended oils.
  - The following oils are recommended (10-liters):
    - TELLUS 33 (SHELL)
    - TERESSO 52 (ESSO)
    - NUTO 32 (ESSO)
    - 343 HYDRAULIC (GULF)
2. After filling the oil tank, return the filler cap and cover to normal position. Replace the handle, to facilitate opening the cover, and also the command lever.
3. Clean the machine with biodegradable soap to eliminate any bacteria that might be present.
4. When the machine has started operating, check the start/stop push-buttons and all safety devices for proper operation.
5. Make sure that the hydraulic pump rotates in the correct direction.
  - CHECK HYDRAULIC PUMP: Press the green start switch (I), then push pedal forward. If the meat pressing piston does not move, the motor is rotating in the wrong direction. To correct this problem, the two cores in the plug wire must be interchanged.

## 3.OPERATION

### Product Function

The piston stuffer is intended for filling natural or synthetic skins with various types of meat without bone parts, flesh, or tendons.

The piston stuffer is completely made of stainless steel (with the exception of the piston and cover, which are manufactured in corrosion resistant anodized aluminum). The piston and cover can be provided in stainless steel as an option. The piston stuffer is equipped with safety devices for the operator's safety.

The machine has been designed in such a way that it is easy to clean and minimal maintenance is required. The machine is also fitted with wheels so it can be moved when required. The piston stuffer construction fulfils all EEC safety requirements:

- The machine is prevented from starting up unexpectedly when the electric supply is restored after electricity is cut.

- As the machine is accessible from all sides, the stop push-button can also be used as an emergency stop.
- The hydraulic oil tank is tightly closed to prevent any risk of explosion or ignition in the machine in case it comes into contact with an electric spark.

## Recommended Use

- The minimum temperature of the meat to be processed must be not less than +1° C(34°F.)
- It is not advisable to use the machine to stuff frozen meat.
- Any use different from the recommended use is not allowed and may be dangerous for the machine and the operator. Promax Equipment LLC is not liable for damage to humans, animals, or material objects resulting from uses that are not expressly described in this owner's manual.
- Always and only use the attachments supplied.
- Only one operator at a time can operate the machine.
- For working operations, the operator must stay in front of the start/stop push-buttons.

## Operation

After completing the startup procedures, work can resume as follows:

1. Loosen nut and open cylinder cover.
2. Load the cylinder with meat.
  - It is recommended that the operator press the meat down with his/her hands to expel as much air as possible from the cylinder.
3. Then choose the correct stuffing horn and fix the selected horn to the cover with nut.
4. Push lever forward to lift piston and release the lever so that it springs back to neutral position.
5. Move lever backward to bring the piston down.
6. When the piston reaches the lowest point, a safety valve will open to prevent stress on the machine.
7. To select the meat output speed desired, adjust command.



- INCREASING SPEED: Turn clockwise to increase the pressure.
- DECREASING SPEED: Turn counterclockwise to decrease pressure.

## 4.MAINTENANCE

### Cleaning

Every environment and application is different; therefore, Promax LLC cannot provide cleaning instructions to guarantee microbiological sanitation. Promax Equipment requests that the owner of this machine consult with sanitation experts to review the unit working in their particular environment to develop a robust cleaning schedule and methodology, followed by bacterial testing to ensure satisfactory cleaning procedures are followed.

### Cleaning Recommendations

**DANGER** Hazardous voltage.

Disconnect and lockout power before servicing machine or cleaning. Do not remove cover on hoist unless power has been disconnected and locked out at risk of electric shock hazard.

1. Clean the machine in accordance with instructions in this section.
2. Always clean the machine after use.
3. Place the machine in a hygienically appropriate environment.

To clean the piston, dismount as follows: Move piston to its highest point. Place part into part and turn counterclockwise in order to unscrew and remove part. This operation must be carried out with pedal pressed forward to prevent eye from turning. Then screw on part into part to remove piston.

To replace piston, place it horizontally on the cylinder, with piston shaft at the top.

To get the piston back into the cylinder, keep screwing on part.

### Maintenance

The piston stuffer has been made to reduce maintenance almost to zero. We recommend that the hydraulic oil be changed approximately every two years depending on usage.

# Troubleshooting

## Problems and Remedies

Problem	Indications	Remedy
The piston stuffer does not go into motion.	Electric power can be lacking.	The operator must wait.
	Button on head blocked or dirty.	Remove blockage from button or clean it.
	The power switch has deteriorated.	Replace power switch.
The piston stuffer stops after being in operation.	There may be a direct contact inside the motor.	The motor will have to be rewound.
	Defective insulation in some feed wire or in the machine control circuit.	It will have to be checked with a voltage meter and the defective wire replaced.
The motor is on, but the machine does not operate.	The pump rotates counterclockwise.	Correct by interchanging the two cores in the plug wire.
	Lack of oil.	Add more oil.
The piston moves up irregularly.	There is air in the hydraulic circuit.	Raise and lower the piston a couple of times to expel air.
	Lack of oil.	Add more oil.

## 5.ELECTRICAL DIAGRAM

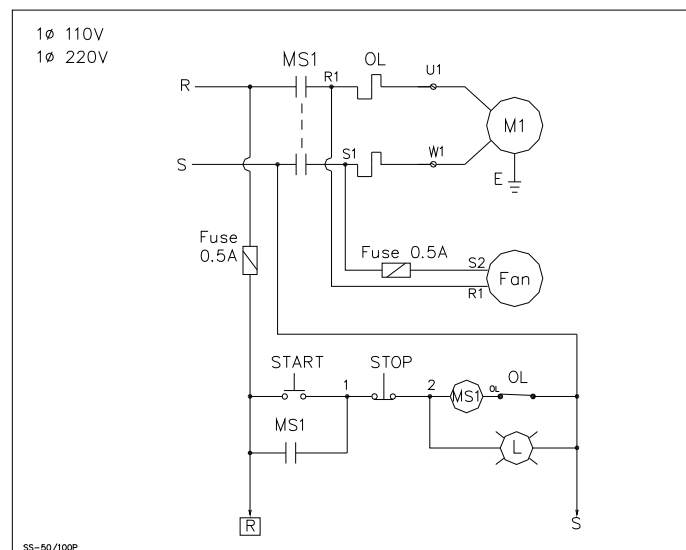

# 6.PARTS-SS50P

## Stainless cylinder Diagram

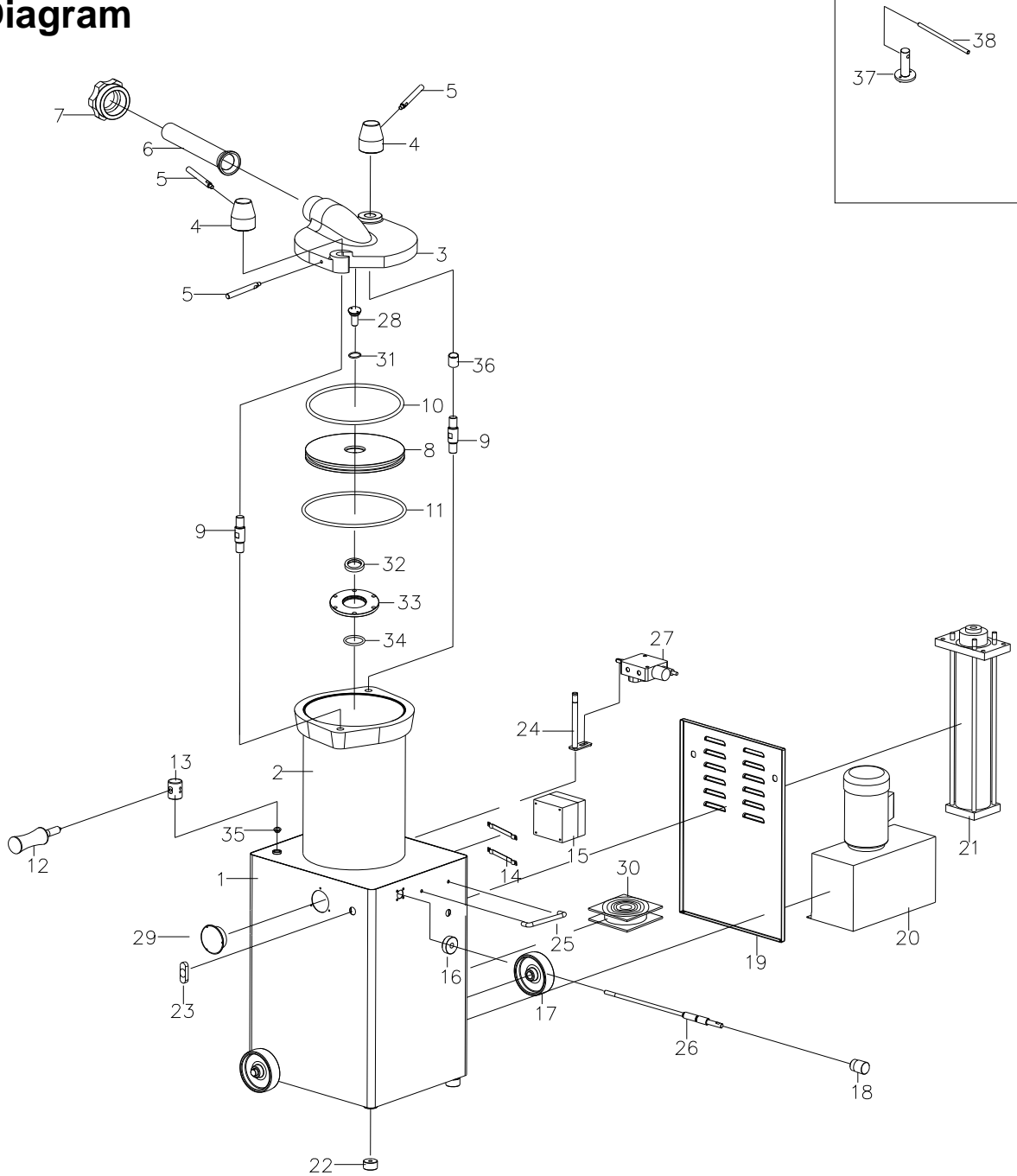

SS25100000

## Parts List

Item No.	Mfg. Part No.	Description	QTY	NOTE
1	SS25101003	FRAME	1	
2	SS25112003	STORAGE TANK	1	
3	SS25120000	TANK OUTER COVER	1	
4	SS25118002	TOP COVER HANDLE MOUNT	2	
5	SS25123000	TOP COVER HANDLE	3	
6	SS25130000	NOZZLE	1	
7	SS50129000	NOZZEL FIXED NUT	1	
8	SS25113001	PISTON	1	
9	SS25116002	COVER FIXED SHAFT	2	
10	27401580	O ring,P295	1	
11	27401571	O ring,P270	1	
12	SS25109002	HANDLE	1	
13	SS25108001	HANDLE BUSHING	1	
14	SS25111001	FIXED PLATE	2	
15	2875319	ELECTRICAL BOX	1	
16	SS50105000	FLOW CONTROL MOUNT	1	
17	PB20102000	CASTER	2	
18	2883137	SPIRAL HANDLE	1	
19	SS25110000	COVER DOOR	1	
20	SS25406000	OIL PRESSURE UNIT	1	
21	SS25402002	CYLINDER	1	
22	SS25102003	FOOT PAD	2	
23	28701851	DURAL BUTTON	1	
24	SS25103001	LIFT ROD	1	
25	SS25124000	HANDLE	1	
26	SS25104000	ADJUST SHAFT	1	
27	2932000	MANUAL VALVE	1	
28	SS25121001	PISTON FIXED SHAFT	1	
29	2910580	PRESSURE GAUGE	1	
30	2813507	FAN	1	OPTION
31	27401544	O ring,G55	1	
32	274005242	OIL SEAL-DH45	1	
33	SS25138000	HYDRAULIC CYLINDER SEAL RETAINER	1	
34	2740188	O RING-G90	1	
35	27281515	BEARING PFF1515	1	
36	27283414	BEARING BM2830	1	
37	SS50135000	PLUNGER PULLING	1	
38	SS50136000	SHAFT	1	

# 6.PARTS-SS100P

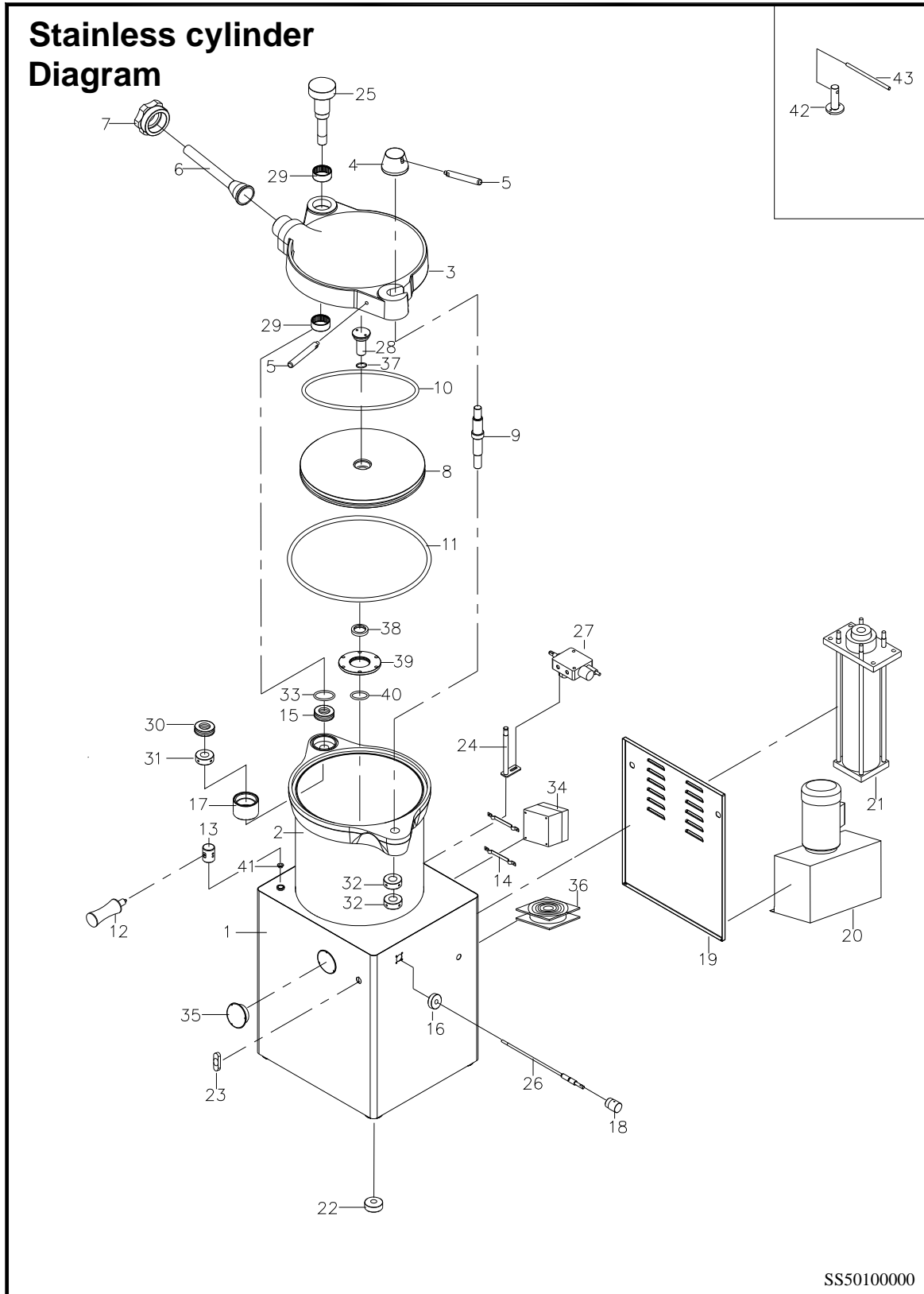

## Parts List

Item No.	Mfg. Part No.	Description	QTY	NOTE
1	SS50101000	FRAME	1	
2	SS50112000	STORAGE TANK	1	
3	SS50120000	TANK OUTER COVER	1	
4	SS50118001	TOP COVER HANDLE MOUNT	1	
5	SS50123000	TOP COVER HANDLE	2	
6	SS50130000	NOZZLE	1	
7	SS50129000	NOZZEL FIXED NUT	1	
8	SS50113000	PISTON	1	
9	SS50124001	COVER FIXED SHAFT	1	
10	2740150	O ring P400	1	
11	SS50119000	O ring	1	
12	SS25109001	HANDLE	1	
13	SS25108000	HANDLE BUSHING	1	
14	SS50111001	FIXED PLATE	1	
15	27289545	BEARING 51209	1	
16	SS50105000	FLOW CONTROL MOUNT	1	
17	SS50127000	BEARING COVER	1	
18	2883137	SPIRAL HANDLE	1	
19	SS50110000	COVER DOOR	1	
20	SS50410000	OIL PRESSURE UNIT	1	
21	SS50402000	CYLINDER	1	
22	SS50102002	FOOT PAD	4	
23	28701851	DURAL BUTTON	1	
24	SS50103000	LIFT ROD	1	
25	SS50116000	TANK FIXED SHAFT	1	
26	SS50104000	ADJUST SHAFT	1	
27	2932000	MANUAL VALVE	1	
28	SS50121000	PISTON FIXED SHAFT	1	
29	27289050	BEARING TA5025	2	
30	27289530	BEARING 51306	1	
31	SS50126000	NUT	1	
32	SS50125001	NUT	2	
33	27401801	O ring P80	1	
34	2875319	ELECTRICAL BOX	1	
35	2910580	PRESSURE GAUGE	1	
36	2813507	FAN	1	OPTION
37	27401544	O ring G55	1	FOR PISTON FIXED SHAFT
38	27400540	OIL SEAL-DH65	1	
39	SS50140000	HYDRAULIC CYLINDER SEAL RETAINER	1	
40	27401781	O RING-G105	1	
41	27281515	BEARING PFF1515	1	
42	SS50135000	PLUNGER PULLING	1	
43	SS50136000	SHAFT	1	

# 7.ELECTRICAL BOX

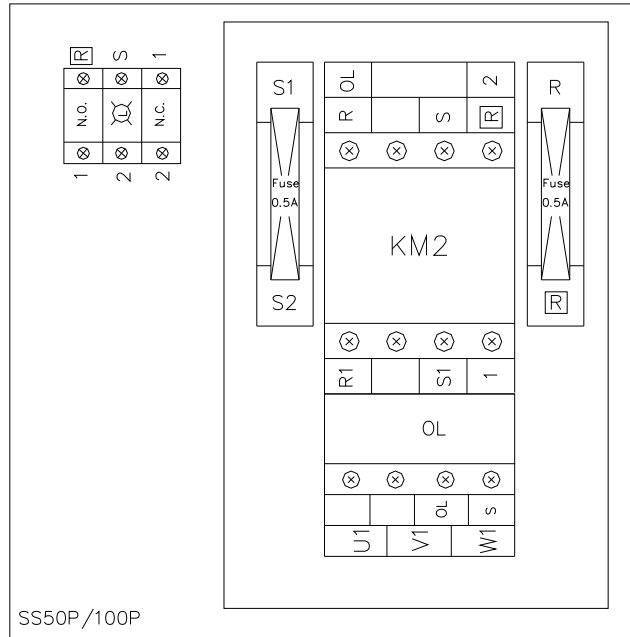

ITEM	PART NO.	DESCRIPTION	SPECIFICATION	Q'TY	FACTORY SETTING	NOTE
KM2	28107587	Contactora	CU-16	1		
OL	2811539	Overload Relay	RHU-10K1(15~20A)	1	19	50P 1 Φ 110V
	2811536	Overload Relay	RHU-10K1(7.2~10A)	1	9	50P 1 Φ 220V
	2811537	Overload Relay	RHU-10K1(11.3~16A)	1	15	100P 1 Φ 220V