



TM-2000S

Vacuum Tumbling Machine

Operation Manual

Version 6.9.1

1915 E. Acacia Street, Ontario, CA91761, U.S.A

TEL : 1-909-923-3888

FAX : 1-909-923-3588

<http://www.promaxvac.com>

S/N:

QC SIGNATURE:

TABLE OF CONTENTS

1. INSTALLATION	1
2. MAINTENANCE	1
3. FUNCTIONS OPERATION.....	1
4. OPERATION.....	2
5. MAINTENANCE INTERVALS AND CHECK ITEMS.....	3
6. MACHINE SPECIFICATION....	4
7. MACHINE OPERATION EXPLAIN.....	5
8. FABRICATION	6
8.1 DRUM BODY.....	7
8.2 MACHINE CASE.....	9
8.3 OPERATOR BOX	12
8.4 ELECTRICAL DIAGRAM	15

1. INSTALLATION

Please check the electric power listed on the vacuum pump and install the vacuum pump correctly,
ground line must on the floor.

2. MAINTENANCE

- A. To ensure vacuum pump works smoothly suggest change the vacuum oil every 500 working hours or every a half year.
- B. Check water filter bottle everyday, as soon as the water over a half of the bottle please cleans it.

3. FUNCTIONS AND OPERATIONS

3.1 (For PV-03)

- 1 LED control panel
- 2 Vacuum switch
- 3 Power switch
- 4 Emergency stop
- 5 Fixed position
- 6 In/Stop/Out switch
- 7 Inhale
- 8 Speed V-R
- 9 Vacuum meter

Cleaning. The tumbler inside must be cleaned everyday after working hours.

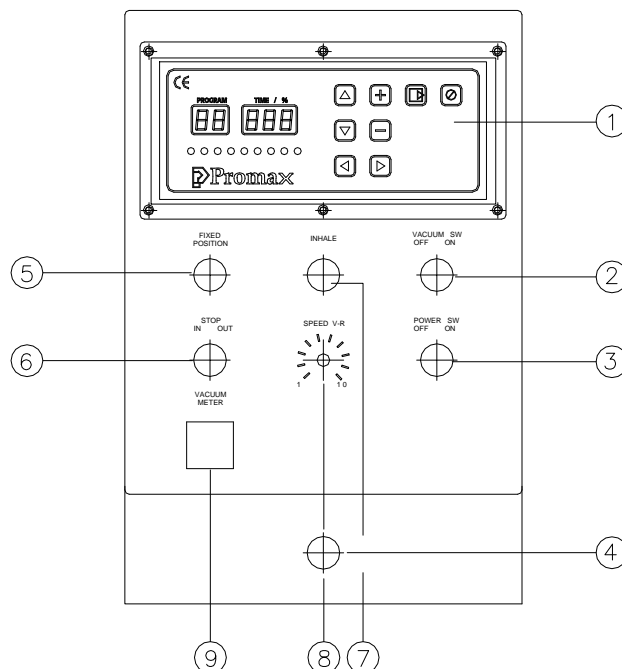

4.OPERATION

PV-03 CONTROL UNIT MANUAL



1. When power on, STB LED light will be on. Wait for 2 seconds; you will be in the operation display.
2. Press “SHIFT” button , you can choose “Mix Time”, “Rest Time”, and “Cycle” , but you just can read “Total Time”, no data input necessary. Because “Total Time=Cycle x (Mix Time + Rest Time).”
3. “Mix Time” and “Rest Time” can input with Hour and Min. If the numbers on the display without “Dot” (On the lower right hand side of display), this means you input the “MINUTES”. If you want to put HOUR, please press the “HR/MIN” button to switch between HOUR and MINUTES display. When the numbers on the display with “Dot”, this means you are inputting the HOUR. °

For example:

In program#1, you plan to input 1hr and 20 min mixing time in the control panel.The way to do:
Shift the Led light on the mixing time
Make the display with “Dot” on the lower right hand side of display. This means you are in the Hour input.

1. Use + button to add 1
2. Press the hr/min button one time switching to MINUTE display. Use + button to add 20 on
On the program#1, having mix time with 1hr and 20 min.
3. Use ▲ and ▼ button to switch the PROGRAM. There are 20 programs memory for saving data. Press + or -button to adjust the value and use the shift button to select the mixing time, rest time and cycle.
4. To activate the tumbler, please press START/PAUSE button once. If you want to stop the operation, you can press STOP CYCLE button. If you want to pause the cycle, please press START/PAUSE button during the operation. If you want to restart the operation, please press the START/PAUSE button again.
5. During the operation, presses HR/MIN, you can check the remaining time for the operation.
6. If the single digit has “dot” on, the number means how many HOURS left. If the single digit has NO “dot”, the number means how many MINTUTES left. To know the total time left, you need to check the Hours and Minutes.

5. MAINTENANCE INTERVALS AND CHECK ITEMS

Check items	Daily	Monthly	Bimonthly	Yearly	Note
Clean and sanitise the machine after use	X				
Check if the safety sensor and reflector are working correctly (for TM150-500/TMC150-1000)	X				
Check vacuum pump oil level before operating the machine	X				
Check the sound of the vacuum pump	X				
Check if oil comes out from the exhaust cover of the pump or not	X				
Check if the chain becomes loose		X			
Change the vacuum oil			X		
Clean the exhaust filter			X		
Replace the exhaust filter				X	
Replace the lid gasket rubber				X	As request

Above mentioned maintenance intervals are scheduled basically for 8 working hours per day

Recommended oil: A. Grav. API 30.5

Pour Pt. -15°C

Flash Pt. 225°C

Viscosity 32.05 CST@40°C

Color Light Yellow

V.I. 100

6.MACHINE SPECIFICATION

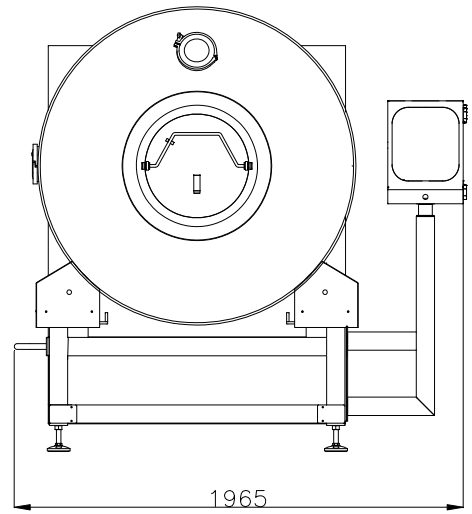
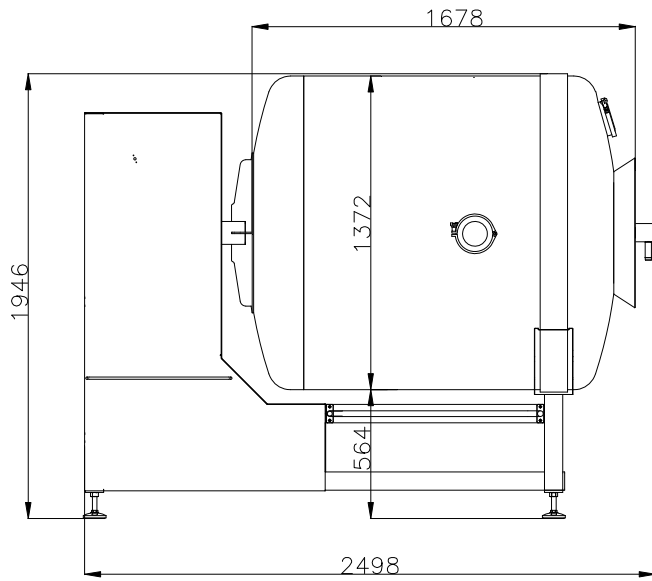

7.MACHINE OPERATION EXPLAIN.

Check the right power source with the name plate of the machine. Plug in the power and ready to operate the machine.

Turn on main power switch and set the value on control panel. After finish all of the setting push down the safety bar and press “Start/Pause” button to start the function. Safety function will be effective and machine will stop at the same time while user pull up the safety bar or gear motor box during working process.

After vacuum tumbling job finish, machine will stop and air ventilation at the same time. As soon as machine finish air ventilation, open the vacuum cover and use unloading switch to unload the product in drum.

The stopper on the side of the machine is design to hold the drum and remain it in the same angle and help user to load in the processing product. How to use the stopper:

- A. Push in the handle bar of stopper to the hole of the drum before load in the processing product.
- B. Pull back the handle bar of stopper from the hole of the drum before start the machine.

Warning: The handle bar of the stopper must be pulled back before user start the machine!! The machine will be damaged if user have not fulfill it!!

8. FABRICATION

8.4 ELECTRICAL BOX

8.1 DRUM BODY

8.3 OPERATOR BOX

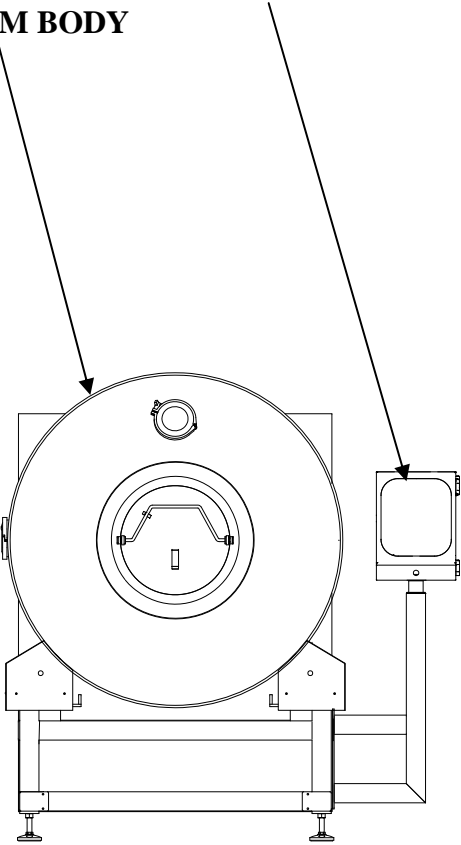
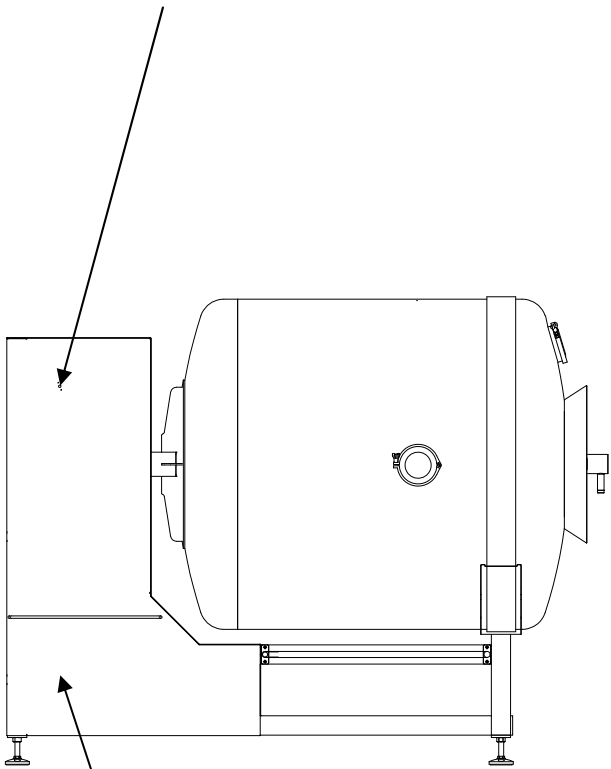

8.2 MACHINE CASE

8.1 DRUM BODY

Drum Body Diagram

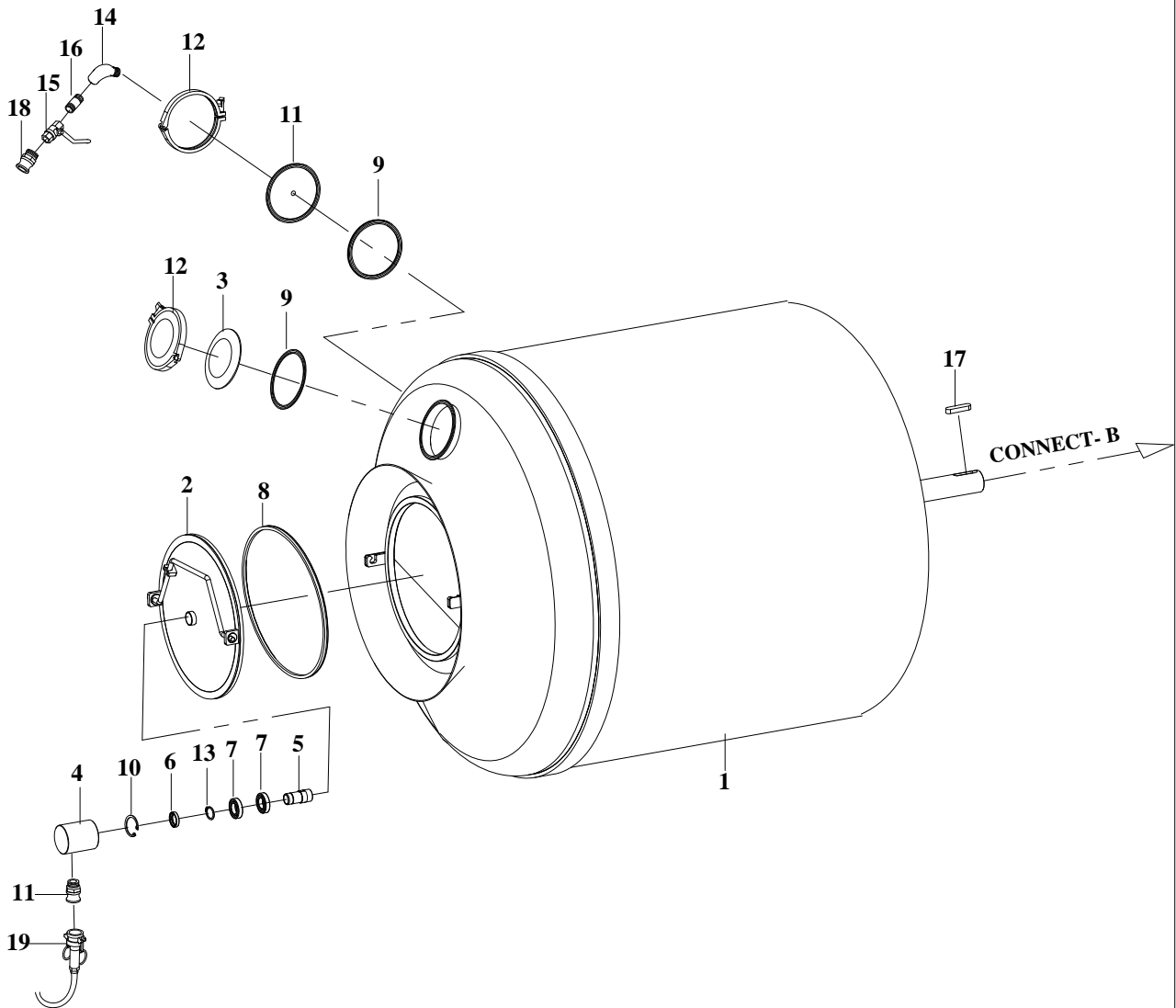

TM2K100000

NO.	PART NO.	DESCRIPTION	QTY	NOTES
1	TM2S201000	Drum tank(TM1000)	1	
2	TM1K202001	Front corver(TM1000,1500)	1	
3	29092251	Adapter IDF-014 6"	1	
4	TM1K204000	Fitting	1	
5	TM1K208000	Fitting	1	
6	274005921	Oil seal D30x42x8	1	
7	27280061	Bearing 6006ZZ	2	
8	3114467	Lid gasket	1	
9	29092254	Gasket IDF-017 6"	2	
10	27062201	Ring R55	1	
11	TM1K206000	Fitting	1	
12	29092253	Heavy duty single pin clamp IDF-015 6"	2	
13	27060091	Ring S30	1	
14	29092621	Fitting 3/4"	1	
15	29095031	Fitting 3/4"	1	
16	29092183	Nipple 3/4"x3cm	1	
17	TM2K231000	Key 22x14x74	1	
18	29093294	Fitting 316 F 3/4"	1	
19	TM1K130A00	Tube	1	

8.2 MACHINE CASE DIAGRAM

Machine Case Diagram

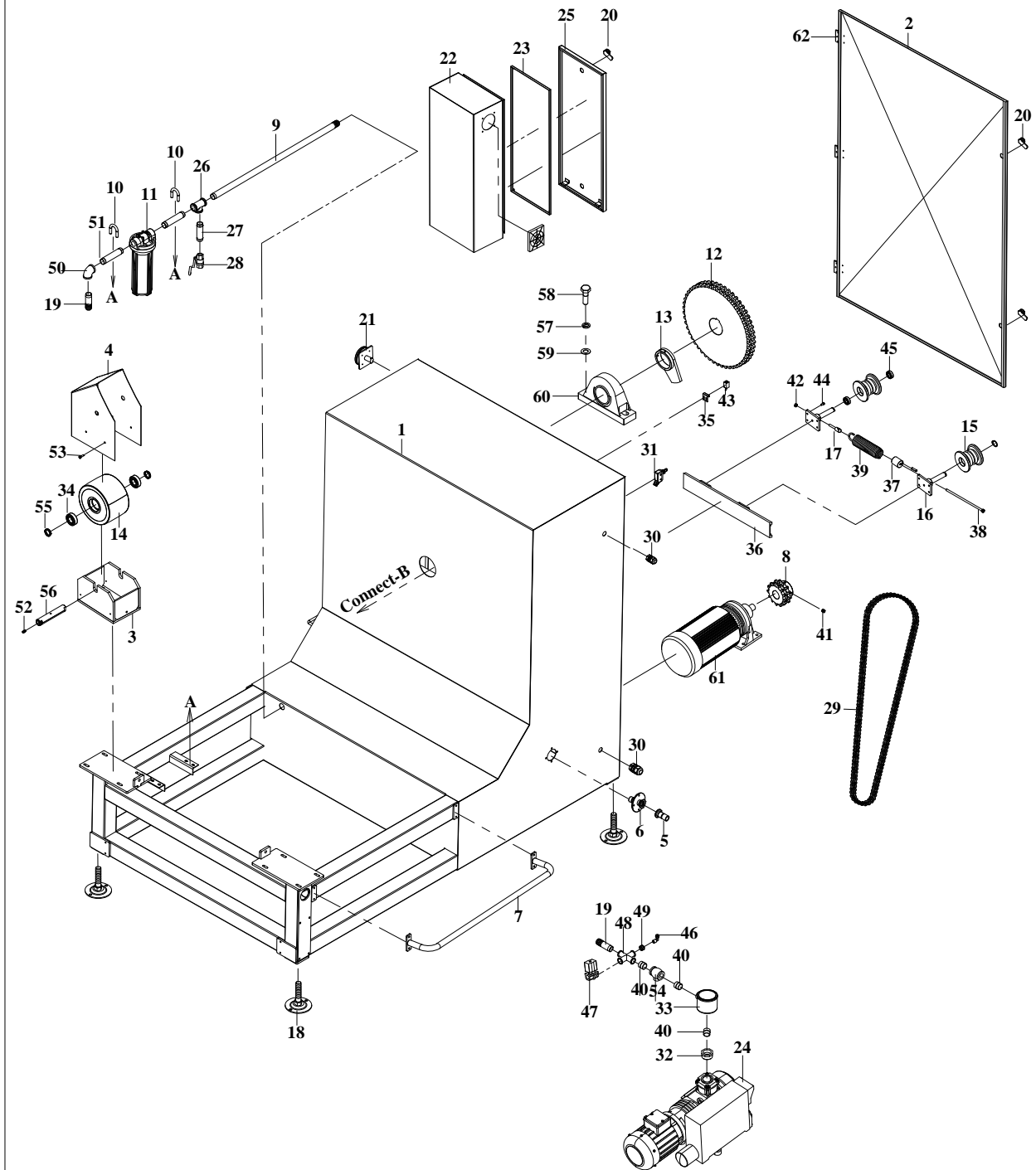

TM2K200000

NO.	PART NO.	DESCRIPTION	QTY	NOTES
1	TM2S101000	Frame(TM2000)	1	
2	TM2S102000	Side door(TM2000)	1	
3	TM2S103000	Wheel fixed plate	2	
4	TM2S112000	Wheel cover	2	
5	TM2S109000	Shaft	1	
6	TM2S107000	Wheel cover	1	
7	TM2S108000	Protect rod	2	
8	TM2S113000	Chain wheel	1	
9	TM2S109000	Fitting	1	
10	27049834	Screw U type 5/16x1"	2	
11	2940004	Filter bottle	1	
12	TM3K127000	Chain wheel	1	
13	TM3K111000	Switch sensor plate	1	
14	TM3K104000	Wheel	2	
15	TM5K119000	Wheel	2	
16	TM5K124001	Wheel fixed plate	2	
17	TM5K126000	Spring mounting bar	1	
18	DC80171000	Base leg	4	
19	TM1K122000	Fitting	2	
20	2883349	Round lock C-408K	4	
21	28017051	Switch	1	
22	TM1K801000	Electrical box	1	
23	TM1K803000	Panel	1	
24	PRA063-230	Vacuum pump	1	
25	147030A4	Electrical box door	1	
26	2740006H	Fitting 3/4"	1	
27	290932782	Nipple 3/4"x9cm	1	
28	29095031	Fitting 3/4"	1	
29	2713076	Chain RS80-2	1	
30	2861025	Straight connector MG20A	2	
31	2853313	Limit switch	1	

NO.	PART NO.	DESCRIPTION	QTY	NOTES
32	29092083	Fitting 3/4"x1-1/4"	1	
33	293080	Air filter 3/4"	1	
34	27280423	Bearing 6206	4	
35	TM2S111000	Sensor fixed plate	1	
36	TM5K140010	Slide mount	1	
37	SC68207000	Holder	1	
38	DC53211000	Spring pull shaft	1	
39	SC68208000	Extension spring	1	
40	29092183	Fitting 3/4"x3cm	3	
41	2704652	Set M10x15	1	
42	2707224	Nut M8	1	
43	28511110	Sensor	1	
44	2700439	Hex head screw M6x25	4	
45	27280044	Bearing 6004	4	
46	29093432	Fitting A036-2	1	
47	29110018	Valve MUV-20-D-AC220V	1	
48	29091507	Fitting 3/4	1	
49	2909141	Fitting 3/4"x1/2	1	
50	2740006A1	Eblow 3/4"	1	
51	290921832	Nipple 3/4x5"	2	
52	2740140	Nipple graese 1/8	4	
53	27004021	Hex head screw M6x20	4	
54	2914059	Valve YORK itap 3/4"	1	
55	TM3K113000	Bushing	4	
56	TM3K105000	Shaft	2	
57	2705334	Split lock washer M22	2	
58	27002051	Hex head screw M22x2.5x70	2	
59	27051291	Washer M22	2	
60	272855713	Bearing pillow block UCP216	1	
61	28144081	Motor LH40-3700-60-S3M 5HP	1	
62	28831391	Hinge	3	

8.3 OPERATOR BOX

Operator Box

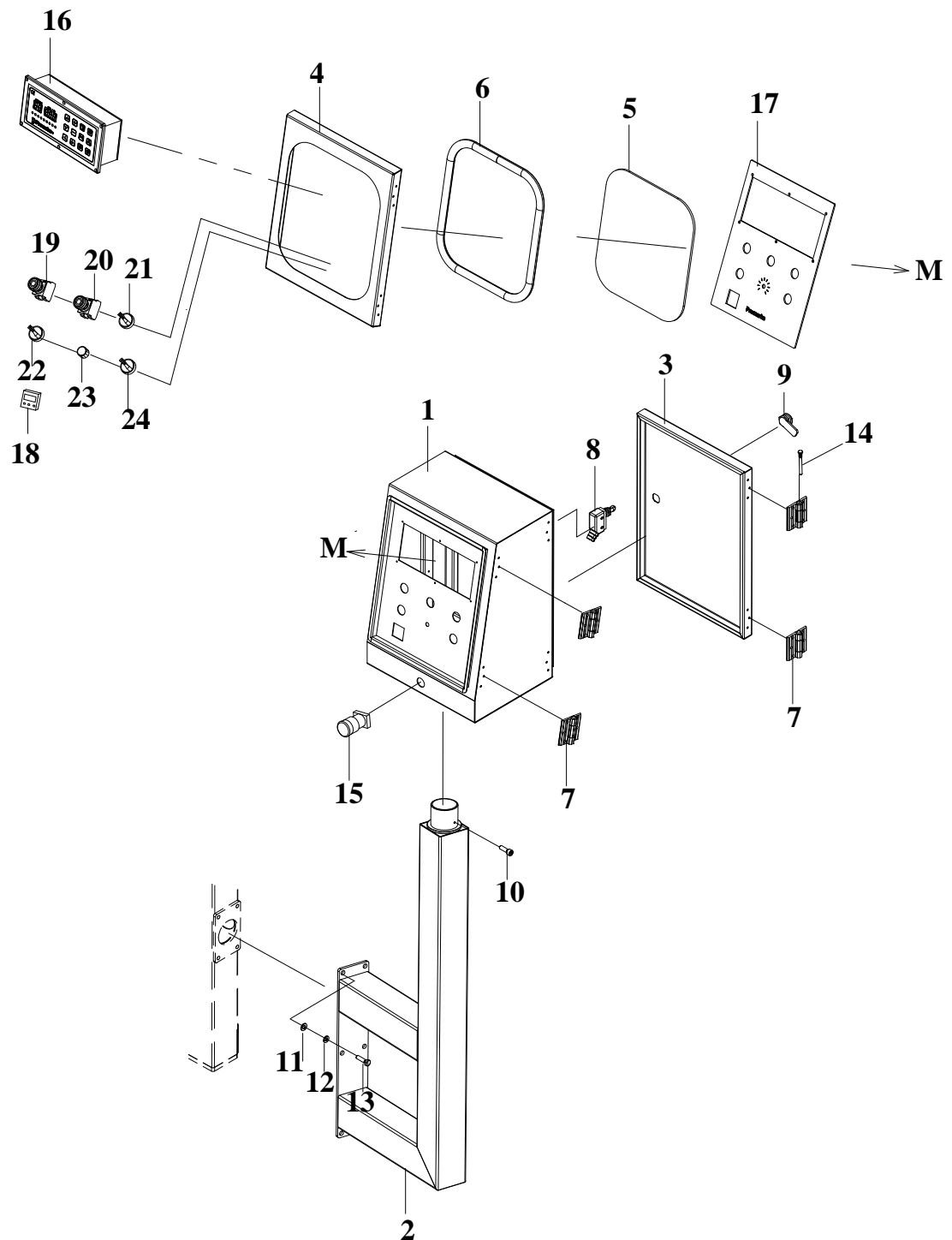

TM1K800000

NO.	PART NO.	DESCRIPTION	QTY	NOTES
1	TM1K811002	Operation box	1	
2	TM1K806001	Operation box support base	1	
3	TM1K813001	Operation box back-cover	1	
4	TM1K814011	Operation box cover	1	
5	TM1K814020	Window	1	
6	TM1K814030	Gasket L=1020	1	
7	28831391	Hinge	4	
8	2853313	Limit switch	1	
9	2883349	Door lock C408K	1	
10	2701167	Socket, hex hd M5x20 (S)	1	
11	2890132	Washer, flat M10 (S)	4	
12	2705304	Split lock washer M10	4	
13	27004001	Screw, hex hd M10x20 (S)	4	
14	MSK1122000	Pin, hinge	4	
15	2870072	Stop emergency NLB22-R11RI AC220V	1	
16	2874044	Control panel	1	
17	TM1K818000	Control panel plate	1	
18	2961011	Pressure switch(w/cover)	1	
19	2871704	Switch yellow TE ZB4-BA5	1	
	28704940	Button guard ZBPO	1	
20	2871764	Switch blue TE ZB4-BW36	1	
	28704940	Button guard ZBPO	1	
21	2871722	Switch TE ZB4-BD2	1	
22	2871724	Switch TE ZB4-BD3	1	
23	2896418	Switch black	1	
	2896440	Variable resistor		
24	2871782	Switch TE ZB4-BK1243	1	

8.4 ELECTRICAL DIAGRAM

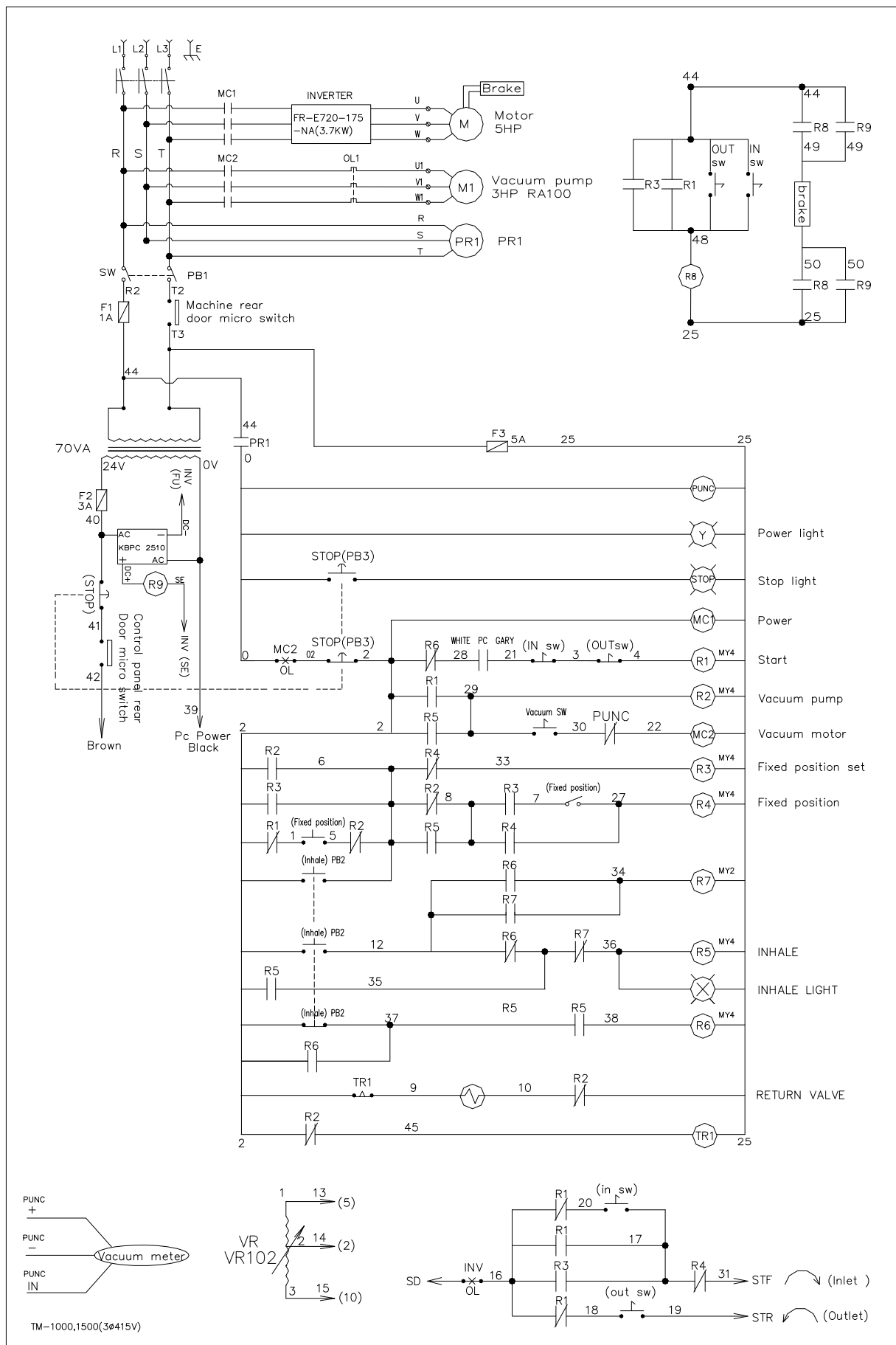

8.4 ELECTRICAL BOX

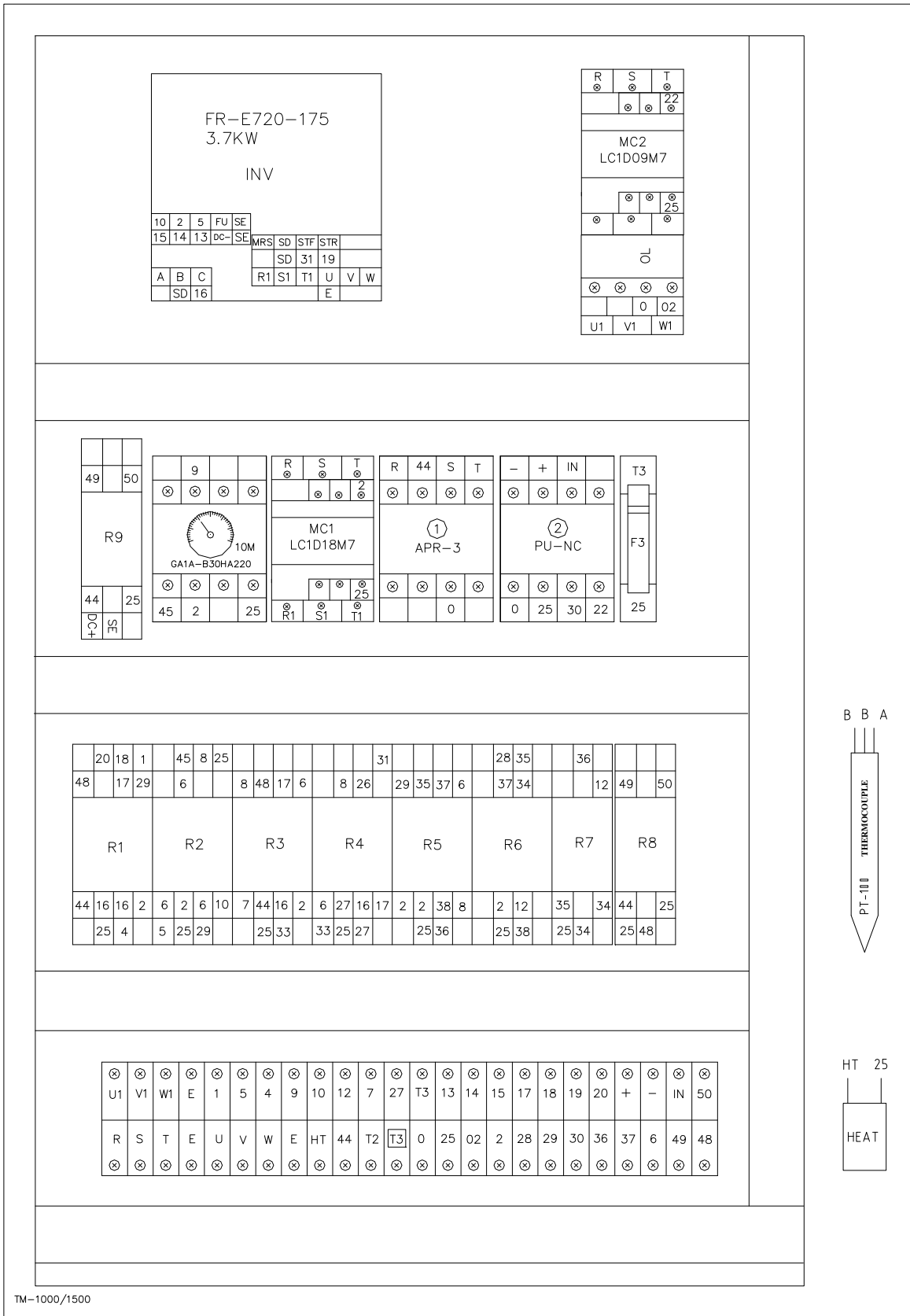

TM-1000/1500

ITEM	PART NO.	DESCRIPTION	SPECIFICATION	Q'TY	NOTE
MC1	28107282	Contactora	TELC1D018M7 (AC220V)F	1	
MC2	28107283	Contactora	TELC1D09M7 (AC220V)F	1	
R1~6	2830197	Relay	RXM4AB-2P7 AC220	6	
	2831106	Socket,Relay	SY4S-05D	6	
R7	2830197	Relay	RXM4AB-2P7 AC220	1	
	2833327	Socket,Relay	PYF08A-C MY2	1	
T1	28960018	Transformer	30VA/0-110-220V.OF- 24V UL	1	3 ϕ 220V
	28960082	Transformer	150VA/380-400- 415V.OF-24V UL	1	3 ϕ 380/400V
KM1 OL	2811645	Relay, Overload	LRD-14(7-10A)	1	3 ϕ 220V
	2811616	Relay, Overload	LRD-012(5.5-8A)	1	3 ϕ 380/400V
IN1	2805424	INVERTER	FR-E720-110-NA	1	3 ϕ 220V TM1000/1500
	2805434	INVERTER	FR-E740-060	1	3 ϕ 380/400V TM1000/1500
QM1	28017051	Switch selector	P1-32/EA/SVB	1	
PU-NC	28560093	Controller	DC12V 50mA (AC220)	1	
	2833202	Socket	PF-085A	1	
APR-3	2830154	Relay	APR-3S AC208-440V	1	
	2833202	Socket	PF-085A	1	
T.B	2843204	Terminal,block	PUW-20	23	
	2843202	Terminal,block	PTU-20L	2	