



TM-150/300/500

Vacuum Tumbling Machine

Operation Manual

Version 6.9.1

1915 E. Acacia Street, Ontario, CA91761, U.S.A

TEL : 1-909-923-3888

FAX : 1-909-923-3588

<http://www.promarksvac.com>

S/N:

QC SIGNATURE:

TABLE OF CONTENTS

1. INSTALLATION	1
2. MAINTENANCE	1
3. FUNCTIONS OPERATION.....	1
4. OPERATION.....	2
5. MACHINE SPECIFICATION....	3
6. MACHINE OPERATION EXPLAIN.....	4
7. FABRICATION	5
7.1 DRUM BODY.....	6
7.2 MACHINE CASE.....	8
7.3 ELECTRICAL BOX	12

1. INSTALLATION

Please check the electric power listed on the vacuum pump and install the vacuum pump correctly,
ground line must on the floor.

2. MAINTENANCE

- A. To ensure vacuum pump works smoothly suggest change the vacuum oil every 500 working hours or every a half year.
- B. Check water filter bottle everyday, as soon as the water over a half of the bottle please cleans it.

3. FUNCTIONS AND OPERATIONS

- 1 LED control panel
- 2 Vacuum
- 3 Caution
- 4 Reset
- 5 Barrel speed
- 6 Forward/Reverse switch
- 7 Vacuum pump ON/OFF switch
- 8 Mixing motor ON/OFF switch

Cleaning. The tumbler inside must be cleaned everyday after working hours.

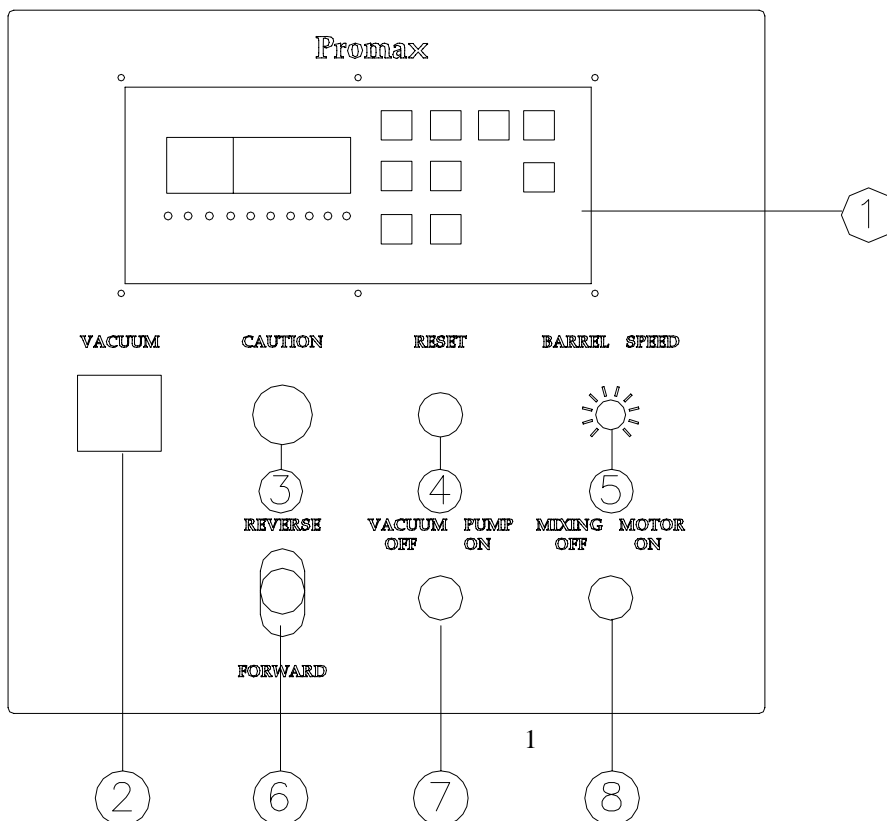

4. OPERATION

PV-03 CONTROL UNIT MANUAL



1. When power on, STB LED light will be on. Wait for 2 seconds; you will be in the operation display.
2. Press “SHIFT” button , you can choose “Mix Time”, “Rest Time”, and “Cycle” , but you just can read “Total Time”, no data input necessary. Because “Total Time=Cycle x (Mix Time + Rest Time).”
3. “Mix Time” and “Rest Time” can input with Hour and Min. If the numbers on the display without “Dot” (On the lower right hand side of display), this means you input the “MINUTES”. If you want to put HOUR, please press the “HR/MIN” button to switch between HOUR and MINUTES display. When the numbers on the display with “Dot”, this means you are inputting the HOUR. °

For example:

In program#1, you plan to input 1hr and 20 min mixing time in the control panel. The way to do:
Shift the Led light on the mixing time

Make the display with “Dot” on the lower right hand side of display. This means you are in the Hour input.

1. Use + button to add 1
2. Press the hr/min button one time switching to MINUTE display. Use + button to add 20 on
On the program#1, having mix time with 1hr and 20 min.
3. Use ▲ and ▼ button to switch the PROGRAM. There are 20 programs memory for saving data. Press + or -button to adjust the value and use the shift button to select the mixing time, rest time and cycle.
4. To activate the tumbler, please press START/PAUSE button once. If you want to stop the operation, you can press STOP CYCLE button. If you want to pause the cycle, please press START/PAUSE button during the operation. If you want to restart the operation, please press the START/PAUSE button again.
5. During the operation, presses HR/MIN, you can check the remaining time for the operation.
6. If the single digit has “dot” on, the number means how many HOURS left. If the single digit has NO “dot”, the number means how many MINTUTES left. To know the total time left, you need to check the Hours and Minutes.

5.MACHINE SPECIFICATION

Model	W	L	H	A	B	C	Capacity
TM-150	1250(49")	940(37")	1380(55")	710(28")	ø561(22")	815(32")	70Kg
TM-300	1345(53")	940(37")	1520(60")	810(32")	ø720(28")	800(32")	140Kg
TM-500	1497(59")	940(37")	1590(63")	970(38")	ø860(34")	730(30")	300Kg

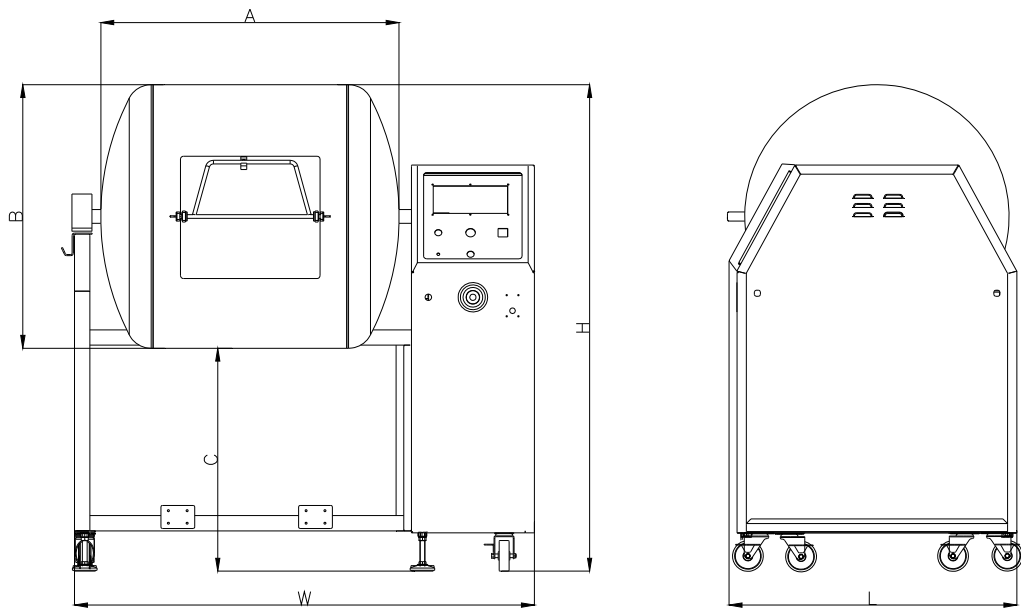
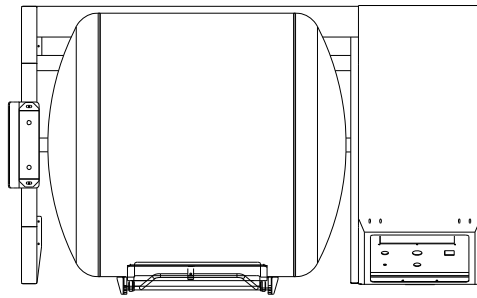

6.MACHINE OPERATION EXPLAIN.

Check the right power source with the name plate of the machine. Plug in the power and ready to operate the machine.

Turn on main power switch and set the value on control panel. After finish all of the setting push down the safety bar and press “Start/Pause” button to start the function. Safety function will be effective and machine will stop at the same time while user pull up the safety bar or gear motor box during working process.

After vacuum tumbling job finish, machine will stop and air ventilation at the same time. As soon as machine finish air ventilation, open the vacuum cover and use unloading switch to unload the product in drum.

The stopper on the side of the machine is design to hold the drum and remain it in the same angle and help user to load in the processing product. How to use the stopper:

- A. Push in the handle bar of stopper to the hole of the drum before load in the processing product.
- B. Pull back the handle bar of stopper from the hole of the drum before start the machine.

Warning: The handle bar of the stopper must be pulled back before user start the machine!! The machine will be damaged if user have not fulfill it!!

7. FABRICATION

7.1 DRUM BODY

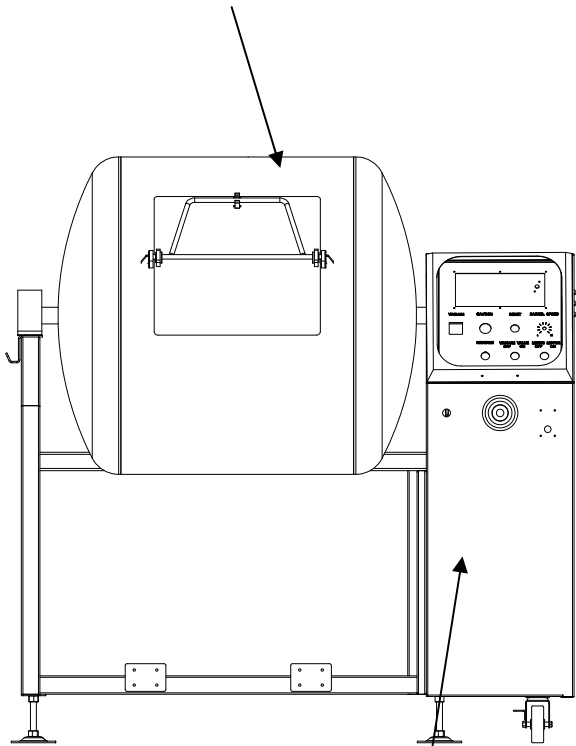

7.2 MACHINE CASE

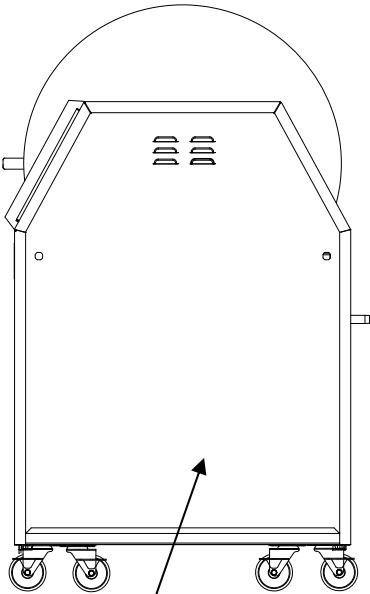

7.3 ELECTRICAL BOX

7.1 DRUM BODY

Drum Body Diagram

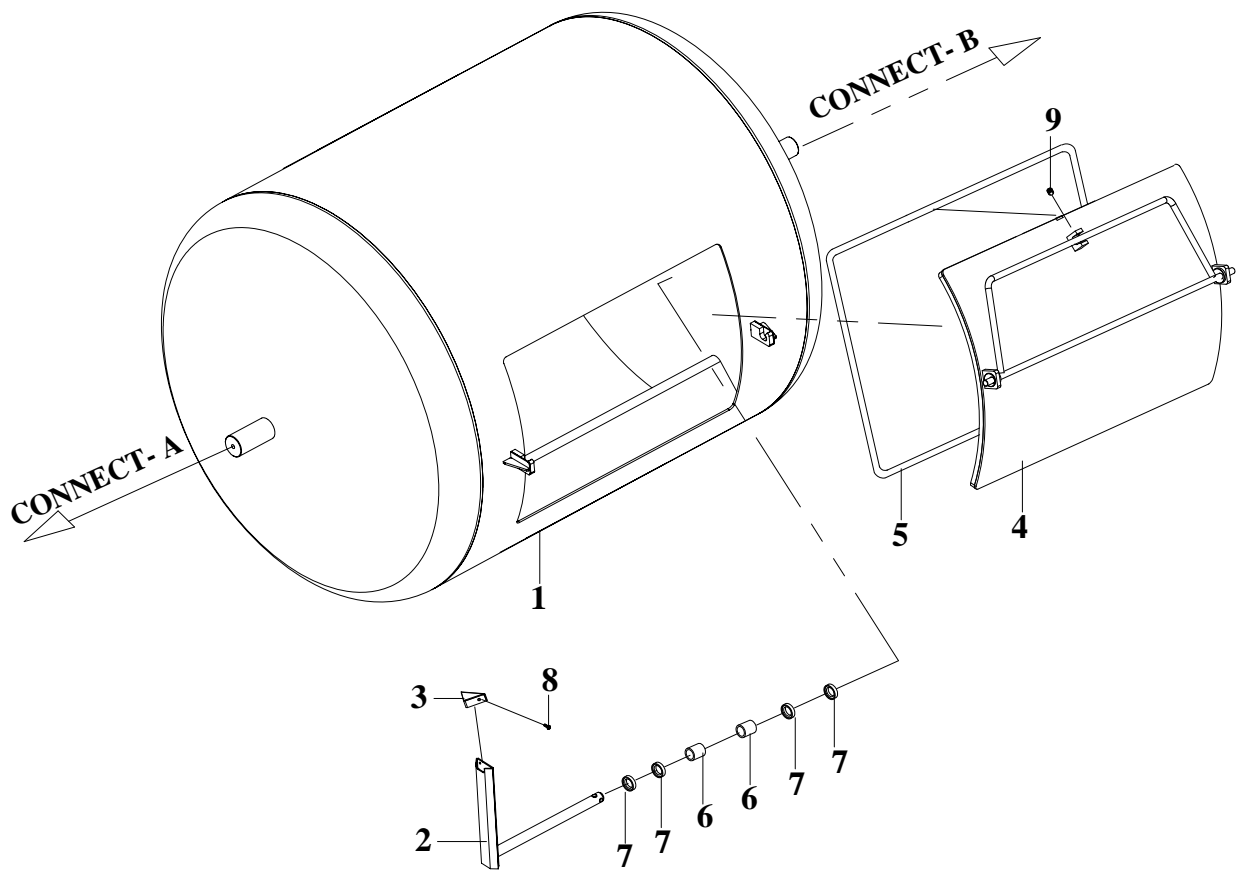

TM50100000

NO.	PART NO.	DESCRIPTION	QTY	NOTES
1	TM15201001	Drum tank(TM150)	1	Option
	TM3H201001	Drum tank(TM300)	1	
	TMA5201002	Drum tank(TM500)	1	
2	TMA1212001	Suck vacuum tube(TM150)	1	Option
	TMA3212001	Suck vacuum tube(TM300)	1	
	TMA5212001	Suck vacuum tube(TM500)	1	
3	TM3H213000	Tube cover	1	
4	TM15220001	Tank cover(TM150)	1	Option
	TM3H220001	Tank cover(TM300)	1	
	TM5H220001	Tank cover(TM500)	1	
5	3114467	Bag retainer silicone	1	
6	2728915	Bearing ASM-2026-30	2	
7	27400597	Oil seal TC20.30.7	4	
8	2701502	Round head screw M5x10	2	
9	2701809	Ball bolt M8x1.25	1	

7.2 MACHINE CASE DIAGRAM

Machine Case Diagram

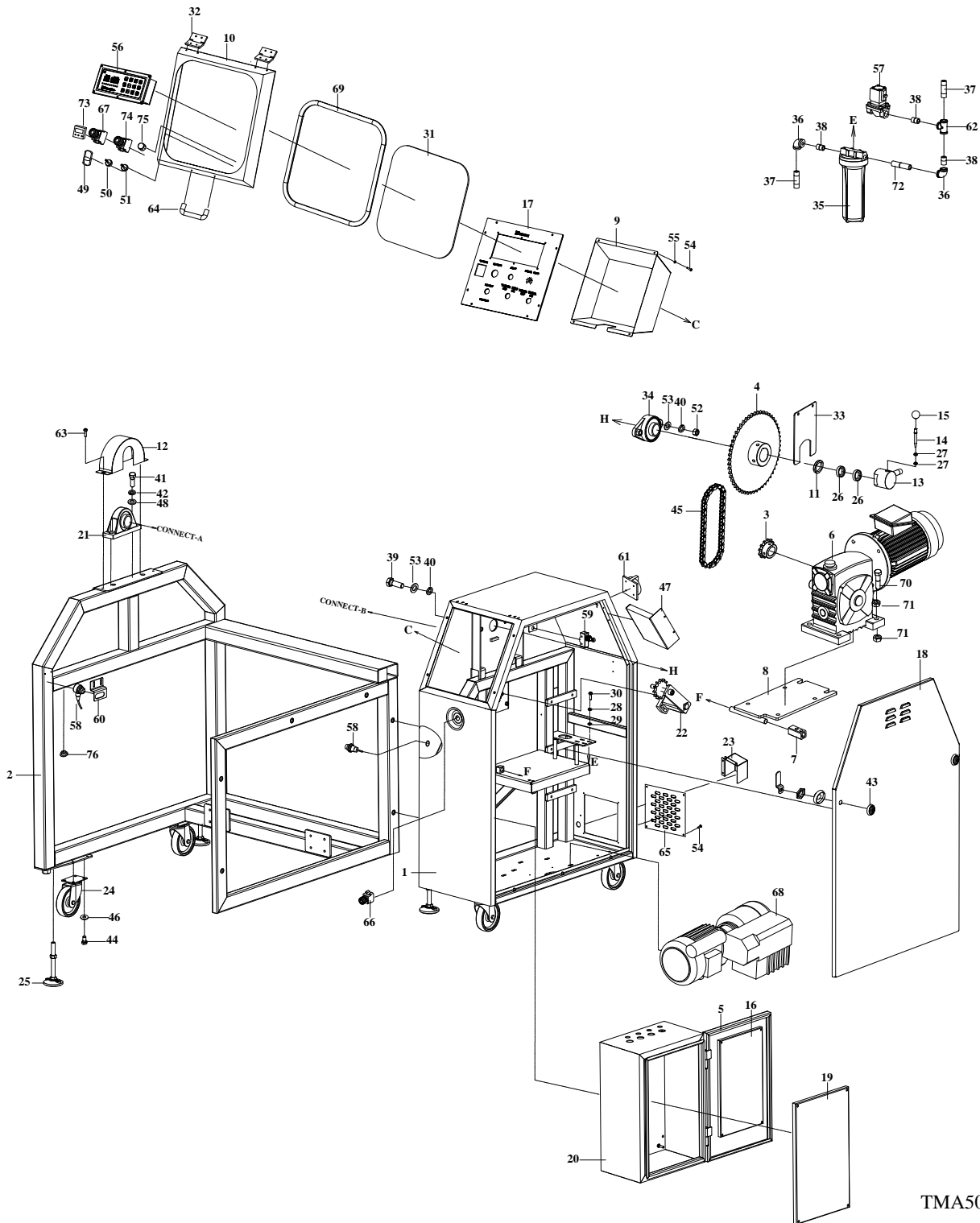

TMA5020000

NO.	PART NO.	DESCRIPTION	QTY	NOTES
1	MC15101003	Frame(TM150)	1	Option
	MC50101005	Frame(TM300,TM500)	1	
2	MC15102005	Side frame(TM150)	1	Option
	MC30102002	Side frame(TM300)	1	
	MC50102004	Side frame(TM500)	1	
3	MC50106001	Chain wheel	1	
4	MC50107000	Chain wheel	1	
5	MC50804001	Electrical door	1	
6	2817043	Motor with reducer AMVF1-4P-U B5	1	
7	MC50121000	Fixed mount	1	
8	MC50122002	Motor fixed plate	1	
9	TM3H129000	Cover plate	1	
10	TM3H130012	Control panel cover plate	1	
11	TM3H219000	Shaft bushing	1	
12	TM3H139000	Cover plate	1	
13	TM3H215000	Vacuum connection	1	
14	TM3H216000	Valve fixed shaft	1	
15	2851053	Pin SR16	1	
16	TM5H803000	Panel	1	
17	TM3H181003	Control panel bottom plate	1	
18	TM3H190000	Side door	1	
19	TM5H802000	Panel	1	
20	MC50801002	Electrical box	1	
21	2728531	Bearing pillow block UCP209	1	
22	2714250	Chain wheel plate RSC-45-50S	1	
23	MC50123000	Cover plate	1	
24	27121411	Casters 4"	4	
25	TM5H121000	Base leg	4	
26	2740059A	Oil seal TC40.55.10	2	
27	27400595	Oil seal TC8.18.7	2	
28	2700408	Hex head screw M8x20	2	
29	2705152	Flat washer M8	2	
30	2705301	Split lock washer M8	2	
31	TM3H130022	Window	1	

NO.	PART NO.	DESCRIPTION	QTY	NOTES
32	28831391	Hinge	2	
33	TMA3103000	Fixed plate	1	
34	2728528	Bearing pillow block UCFL209	1	
35	2940001	Filter bottle	1	
36	274000661	Elbow 1/2"	2	
37	290932569	Nipple 1/2"x60	4	
38	290932570	Nipple 1/2"x30	2	
39	270020291	Hex head screw M16x35	2	
40	2705328	Split lock washer M16	2	
41	270020290	Hex head screw M16x45	2	
42	2705322	Split lock washer M14	4	
43	2883349	Door lock C408K	2	
44	2700402	Hex head screw M6x16	5	
45	2713024-80	Chain	1	
46	2705151	Flat washer M6	5	
47	TM5H116000	Electrical protect plate	1	
48	2705155	Flat washer M14	2	
49	28701852	Button M22DP-SF20GR	1	
50	2871220	Switch YW1S-2E10P	1	
51	2871119	Switch YWIS-2111P	1	
52	27071103	Nut M16	2	
53	2705329	Flat washer M16	2	
54	2703307	Round head screw M4x10	4	
55	2705306	Split lock washer M4	4	
56	2874044	Control panel	1	
57	29118089	Valve VXZ2BOFZIU(AC24V)	1	
58	28506131	Sensor	1	NOTE1
59	2853313	Limit switch	1	
60	TM5H117000	Sensor plate	1	
61	28017051	Switch	1	
62	29090097	Tee branch valve 1/2"	1	
63	2701501	Round head screw M6x12	2	
64	2883343	Handle	1	
65	TM3H145000	Cover plate	2	
66	2870069	Switch, AC24V1A1B, emergency stop	1	

NO.	PART NO.	DESCRIPTION	QTY	NOTES
67	2872503	Button SCR-3041	1	
68	PRC020-110	Vacuum pump 110V	1	OPTION
	PRC020-220	Vacuum pump 220V	1	
69	2714752	Gasket L=1230	1	
70	27004560	Hex head screw M14x40	4	
71	27070094	Nut M14	4	
72	29093279	Nipple 1/2"x10cm	1	
73	2961018	Pressure switch, For S/N#PF13102424 to S/N#PF15062523	1	OLD VERSIO N NEW VERSIO N
	2961019	Holder(w/cover), F/Pressure switch P/N#2961018		
	2961011	Pressure switch(w/cover), For S/N before PF13102424 and after PF15062523		
74	2870049	Switch green YW1B-M1E10G	1	
	28704940	Button guard ZBPO		
75	2896411	Variable resistor	1	
	2896418	Switch black		
76	TM5H118000	Plug	1	
NOTE1 OLD P/N#2850608 HAS BEEN AMENDED TO NEW P/N#28506131 FROM S/N#PF5003032				

7.3 ELECTRICAL DIAGRAM(110V)

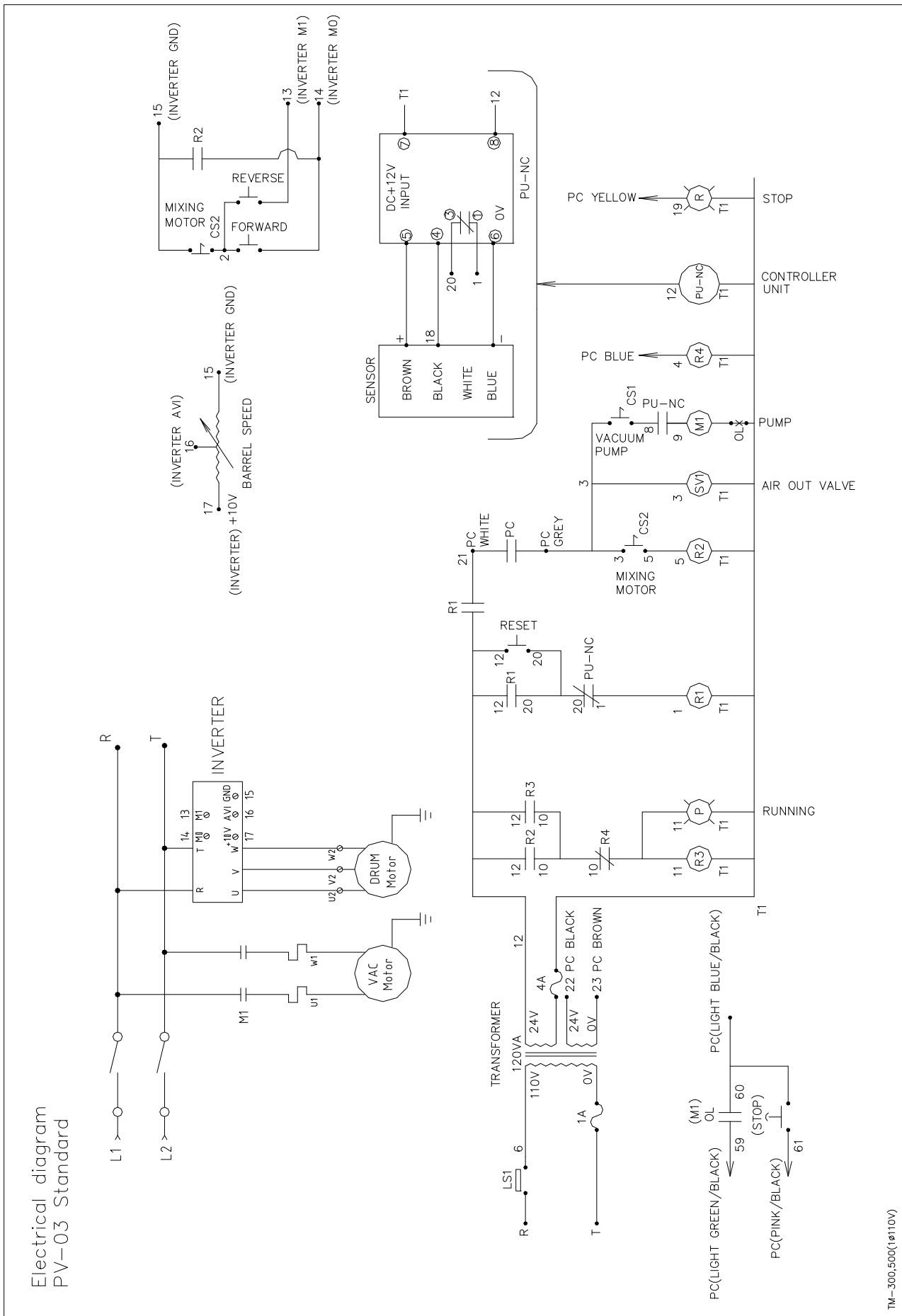

TM-300,500(1ø110V)

7.3 ELECTRICAL DIAGRAM(220V)

Electrical diagram
PV-03 Standard

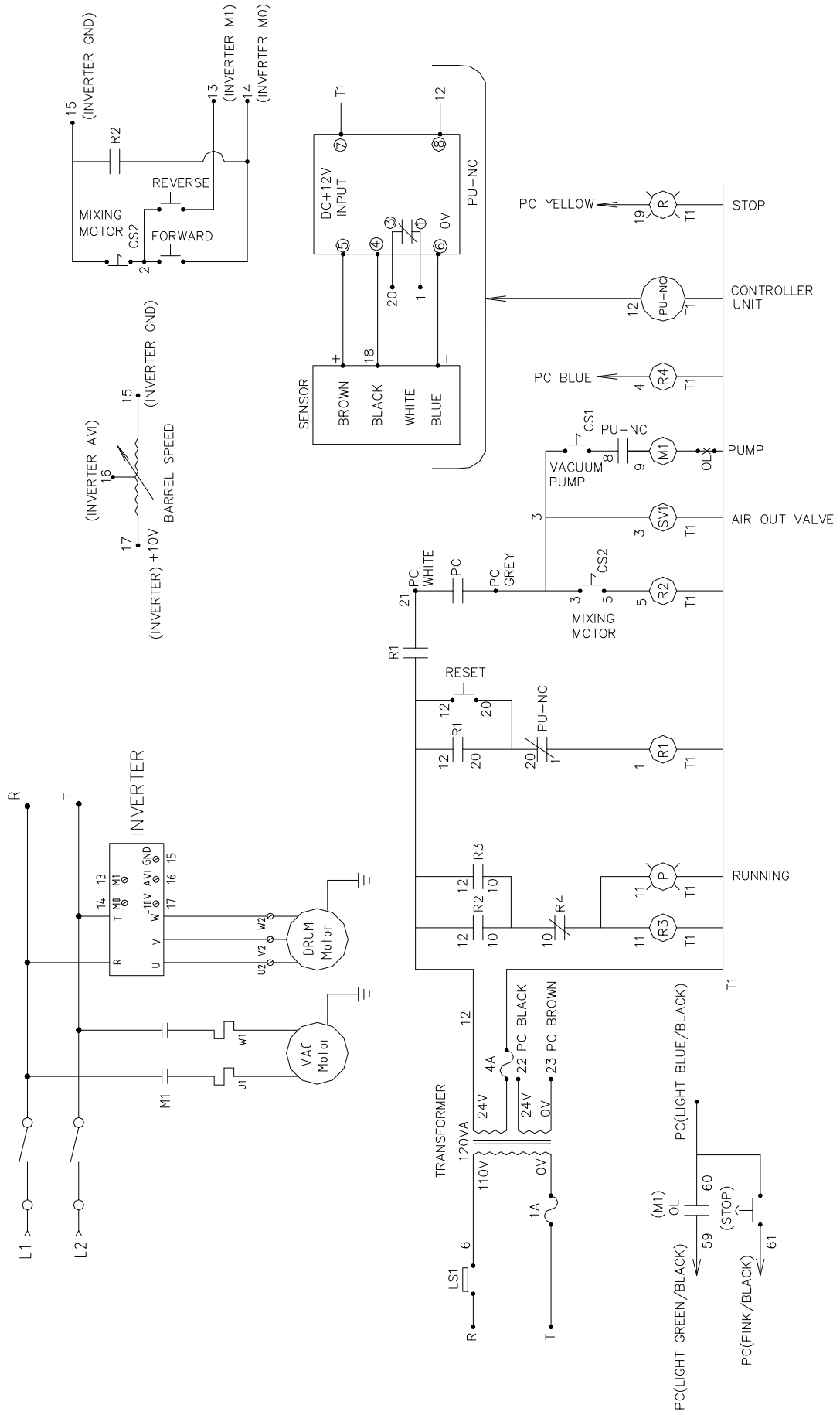

TM-300.500(1w220V)

7.3 ELECTRICAL BOX

ITEM	PART NO.	DESCRIPTION	SPECIFICATION	Q'TY	NOTE
KM1	2810739	Contactora	CU-11-B5 (AC24V)	1	
R1~5	2830132	Relay	RU4S-C-A24	1	
	2831106	Socket,Relay	SY4S-05D	1	
T1	28960025	Transformer	120VA/110V.OF-24V UL	1	1 ϕ 110V
	28960020	Transformer	120VA 0F-200-220/0- 24, 0F-24 UL	1	1 ϕ 220V
	28960023	Transformer	120VA 0F-400-440/0- 24, 0F-24 UL	1	3 ϕ 400V
KM1 OL	2811539	Relay, Overload	RHU-10K1(15-20A)	1	1 ϕ 110V 20PUMP
	2811538	Relay, Overload	RHU-10K1(11.3-16A)	1	1 ϕ 110V 21PUMP
	2811535	Relay, Overload	RHU-10K1(5.5-7.5A)	1	1 ϕ 220V 21PUMP
	2811530	Relay, Overload	RHU-10K1(1.8-2.5A)	1	3 ϕ 380/400V 21PUMP
IN1	2805128	INVERTER	VFD007S11A	1	1 ϕ 110V TM500
	2805135	INVERTER	VFD004S11A	1	1 ϕ 110V TM150.TM300
	2805057	INVERTER	VFD004S21A	1	1 ϕ 220V TM150/300/500
	2805144	INVERTER	VFD004S43A	1	3 ϕ 380/400V TM150/300/500
QM1	28017051	Switch selector	P1-32/EA/SVB	1	
PU-NC	2856019	Controller	DC12V 100mA (AC24)	1	

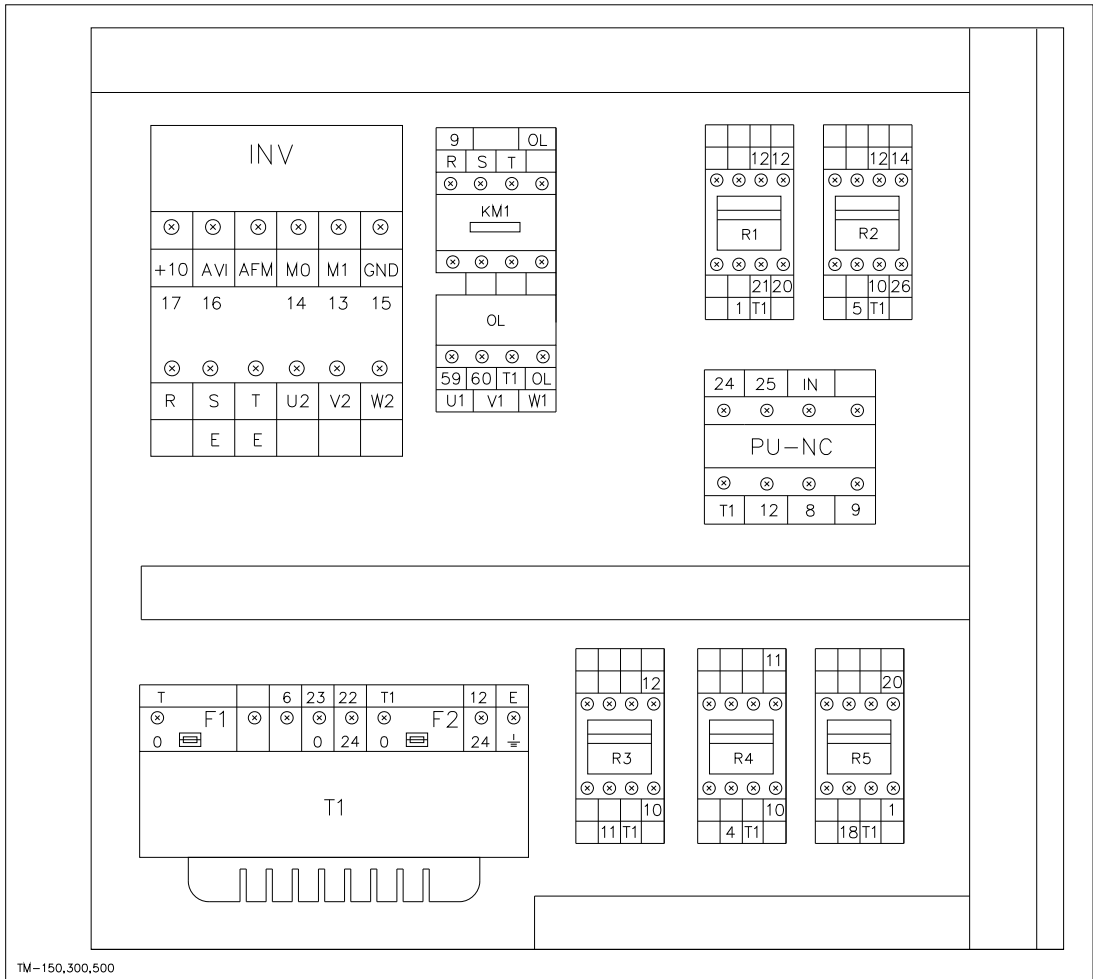

TM-150,500,500