



NZ-1500

Nozzle Type Vacuum Packaging Machine

Operation Manual

Version 6.9.1

1915 E. Acacia Street, Ontario, CA91761, U.S.A

TEL : 1-909-923-3888

FAX : 1-909-923-3588

<http://www.promaxvac.com>

S/N:

QC SIGNATURE:

INDEX

SAFETY RECOMMENDATION	1
1. APPLICATIONS	2
1.1 WHY WE NEED VACUUM PACKAGING	2
1.2 RECOMMENDATION OF VACUUM POUCH.....	2
2. TRANSPORTATION INSTRUCTION	3
3. NZ-1000 SPECIFICATION	4
4. INSTALLATION	4
4.1 ENVIRONMENT REQUIREMENTS	4
4.2 CHECK OIL LEVEL	5
4.3 POWER CONNECTION	5
5. OPERATION	6
5.1 VACUUM SETTING GUIDLINES	6
5.2 BASIC OPERATING INSTRUCTIONS	6
5.3 OPTIONAL DEVICE	6
5.4 LED CONTROL PANEL FUNCTIONS	7
6. MAINTENANCE	12
6.1 BASIC MAINTENANCE	12
6.2 VACUUM PUMP MAINTENANCE	13
6.3 REPLACE AND MAINTAIN THE SEALING BAR	13
6.4 MAINTENANCE INTERVALS AND CHECK ITEMS	15
7. TROUBLESHOOTING	16
7.1 PROBLEMS AND CORRECTIONS	16
7.2 PNEUMATIC DIAGRAM	18
7.3 ELECTRICAL DIAGRAM	19
7.4 ELECTRICAL DIAGRAM	20
8. FABRICATION	21
8.1 FRONT SIDE DIAGRAM	22
8.2 AFTER SIDE DIAGRAM	26
8.3 ELECTRICAL BOX	29

SAFETY RECOMMENDATION

Certain practices or minor modifications on the part of the user may increase the risk of damage and/or accidents.

In the interests of safe installation, handling and maintenance, the following recommendations should be strictly followed:

- 1) Never start or service the machine until all safety sections, installation instructions, operator's guide and maintenance procedures have been read and understood.
- 2) All adjustments and repairs must be carried out only by qualified technicians or maintenance personnel, also have to follow the instructions of this manual to commence.
- 3) The operator must keep hands out of the machine and never insert rags, etc. into machine while it is running.
- 4) Do not put tools, parts or other foreign objects on or into the machine.
- 5) Always keep the machine clean, lubricated and in good working condition.
- 6) To provide continuous protection against the risk of electrical shock, connect the power to proper outlet.
- 7) Always shut down the power (turn off the main power switch) as show on next page before removing service panel.

1. APPLICATIONS

This machine is applied for frozen food, sea food, prepared food, meat, soaked foods, herbal medicines, tea leaves, hardware parts, accessories and electronic products ... etc.

1.1 WHY WE NEED VACUUM PACKAGING

- Keep the freshness and flavor of food, preserve food and prevent from mold.
- Extend storage and shelf life of packed products.
- Prevent electronic and hardware parts from rust and moisture.

The vacuum packaging machines have been designed to guarantee the best preservation and to extend shelf life of any food product that requires protection against oxidation.

In food industry, these products are usually vacuum packed: meat, sausages, ham, bacon, fish, cheese, coffee, pizza, fresh pasta, olives, pickles and many other gastronomy products; and in other fields the following ones: chemical, pharmaceutical and cosmetic products, electronic parts, car spare parts etc.

The fresh meat sector is particularly advantaged by the vacuum technology. Vacuum packaging, in fact, greatly delays any deterioration caused by ambient air; it is an obstacle to the development of bacteria and moulds and markedly reduces the negative effects of temperature changes. Packaging in airless space also gives a slow ripening effect, thus protecting in the best way the organoleptic qualities of the meat.

1.2 RECOMMENDATION OF VACUUM POUCH

In order to have a perfect result after vacuum packaging and provide longer shelf life for packed products, we recommend using vacuum pouches made of NY/LDPE.

2. TRANSPORTATION INSTRUCTION

For the transportation and placing, have a forklift truck available (keep in mind weight of the machine). Precautions to take; Lift the machine by its center of gravity; this is not necessarily the same as the center of the machine. On lifting the machine with the forklift, do so from the front part (that opposite the electrical box). Check for components hanging under the machine.

The machine can be lifted using a suitable forklift. (Secure the gravity of machine before lifting)

Precautions :

- Prior to lifting, the separation of the forks and their length must be taken into account for transportation. Only use the identified lifting points. Do not slide the machine when it is standing on the floor. Make sure the machine is safe to be lifted before starting.
- Lift the machine by using forklift from the front side of machine (i.e., the opposite side of electrical box), except small type machines. Check the components hanging under the machine before lifting, since it may cause machine falling down.
- Always be carefully when proceed lifting or moving.
- The proper lifting and moving of machine (according to the instructions) have to be ensured.
- Weight of the machine is approximate 200 kg or 400 lbs.
- Prior to installing, remove the pallet under the machine and position the machine on floor.

3. NZ-1500 SPECIFICATION

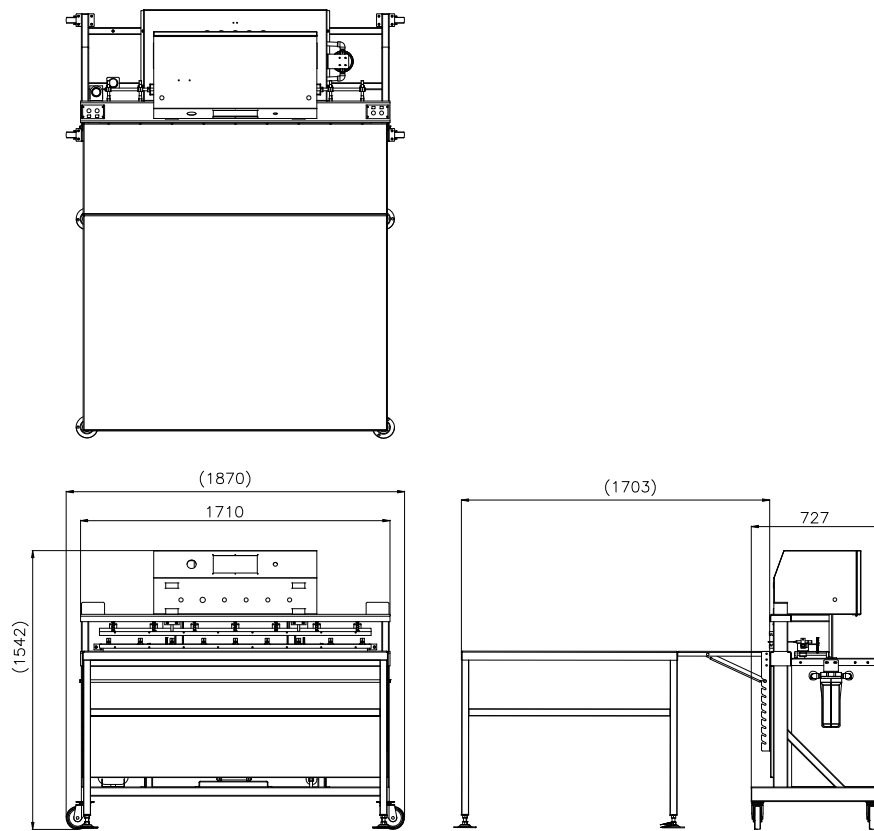

4. INSTALLATION

4.1 ENVIRONMENT REQUIREMENTS

The machine will be started difficultly if the air temperature is very low. Cause the oil will be stiffened and its viscosity will become higher in cold working environment. To prevent from this, please set up machine according to the installation checklist described as below :

- Temperature : around 5 ~ 40°C
- Working elevation : between 0 ~ 1000 meters
- Relative humidity : 30 ~ 95% RH
- During operating, heat is generated by the vacuum pump and vacuum process, so the machine temperature keeping around 70 ~ 80°C is normal. Also must have free air access for cooling.
- A minimum distance from walls, other machines, etc. should be maintained, at least 20 cm for each side of machine for providing adequate ventilation.
- Main air supply pressure to operate the machine : 80 psi.

4.2 CHECK OIL LEVEL

Only check the oil level when the machine is not in operation and depressurized !
The oil might be hot ! Danger of scalding ! Do not spill oil ! Check for leakage !

Check oil level

- Check the oil level after each stop and at regular intervals.
 - The max. oil level is in the upper oil level sight-glass, the min. oil level is in the lower.
- Ensure the oil level is between the upper and lower limits. If required, fill it up to the max. oil level.

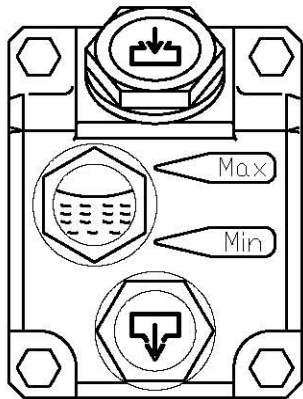

4.3 POWER CONNECTION

Prior to connecting the power, please check the relative information at the back of machine, after make sure the required current, then connect the correct power to the pump and plug in the right outlet. The connection must be done by an authorized personnel. Consult the electrician if you have questions about the electrical supply in your facility.

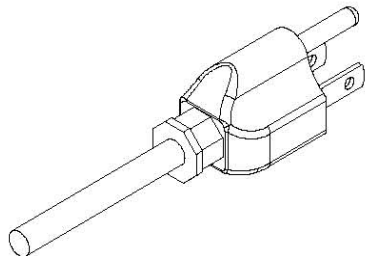

5. OPERATION

5.1 VACUUM SETTING GUIDLINES

Products	Vacuum time/Sec.	Storage life when stored at 2 ~ 6 °C/day
Fresh meat	30	10
Pork	30	10
Beef	30	30
Meat with liquid	15 ~ 30	14
Pasta	3 ~ 9	21
Sliced sausage	15	10
Cold cuts	9	10 ~ 21

5.2 BASIC OPERATING INSTRUCTIONS

Turn on the main switch and the LED display shows the operation menu, at this time, machine is ready to operate.

Place the product to be packaged in a vacuum pouch. Place the bag in chamber with the open end of bag across the sealing bar. (With a package that doesn't completely fill the chamber, place provided flat plates in the chamber to shorten vacuum time.)

Close the lid to start the cycle, the lid will open automatically when cycle is completed.

Take out the sealed product from vacuum chamber. You are ready to start the next cycle.

After all packaging is completed, please let the vacuum pump run for about 15 minutes, then turn off the main switch to shut down the machine.

5.3 OPTIONAL DEVICE

5.3.1 GAS FLUSHING UNIT

If your machine is equipped with an optional gas flush system please note the following points.

Make sure you have connected a regulated gas source to the gas inlet fitting

Do not set your regulator for a pressure of greater than 40psi

Place the open end of your package in front of the gas inlet nozzles

Do not tuck the bag under the gas nozzles

5.4 OPERATION OF THE PNC-01 DIGITAL CONTROL PANEL

5.4.1 Operation of the Model PNC-01 Digital Control Panel

When following the instructions for programming your machine please refer to Fig.5 below.

Figure 5

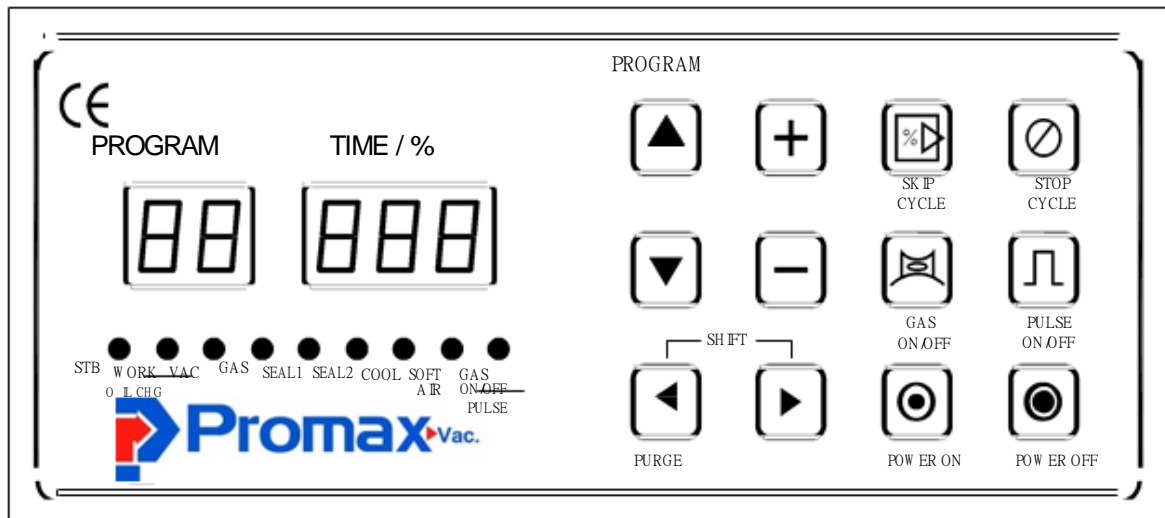

Standard Machine – Basic Instructions

- A. Press the **Main Power** switch located to the right of the control panel.
 1. The Main Power switch will **NOT** light up.
 2. The standby, **STB**, LED on the control panel will light up.
- B. Press the **Power ON** touch pad on the control panel.
 1. The **Program** display and the **Time/%** display will light up.
 2. The **Program** display will indicate what program the machine is running.
 3. The **Time/%** display will indicate the vacuum setting for that program.
- C. **Changing to a different program**
 1. Press either the **Up or the Down** arrow key on the control panel.
 2. You will see the number displayed in the **Program** display change.
 3. Select the program number before the one you want to move to
 4. Press the **Up** arrow key and hold it down for approximately 5 seconds.
 5. You will see the number in the **Program Display** begin to blink.
 6. Press the **Up** arrow key once and it will stop blinking.
 7. Using the **Up / Down** arrows go back to the program number you chose.
 8. **Important:** Cycle the machine 1 time to save program change.

D. Changing Program Settings

1. Choose the program number you wish to edit
2. Press and hold down the **Right Arrow** key for 3 seconds.
3. You will see the **Time / %** display begins to flash.
4. **Change the settings as indicated in steps E to J.**

Important Note: If your machine is equipped with the most recent version of the PNC-01 control you will not need to implement the instructions above in order to change program settings.

E. Vacuum

1. Make sure the **LED** above the word **VAC** is lighted.
2. Using the **Plus/Minus** keys increase or decrease the vacuum time.
3. Press the **Right Arrow** key to move to the next setting.

Important note: You may always use the left arrow key to go back to the previous setting.

F. Gas (Optional) See Optional Settings

1. Using the **Plus/Minus** keys set to 0.00
2. Press the **Right Arrow** key **3X** to move to the next setting.

G. Seal 1

1. Using the **Plus/Minus** keys increase or decrease the seal time.
2. Press the **Right Arrow** key to move to the next setting.
3. Maximum sealing time : 3 seconds.

H. Seal 2: Not used at this time.

I. Cool

1. Using the **Plus/Minus** keys increase or decrease the cooling time.
2. Press the **Right Arrow** key to move to the next setting.
3. Minimum cooling time : 3 -5 seconds.

J. Soft Air: This feature allows the chamber to partially vent in short pulses. Three separate settings are required to complete this operation.

1. The first setting is **Total Vent Time**. Using the **Plus/Minus** keys to set the amount of **Total Vent Time** you want.
2. Press the **Right Arrow** key to move to the next setting. You will see that the soft air LED remains on. However you are now setting the **Vent On time**.
3. Using the **Plus/Minus** keys set the amount of time you want the vent valve to open during each pulse.

Press the **Right Arrow** key to move to the next setting. The Soft Air LED will remain on. However you are now setting the **Vent Off time**.

4. Using the **Plus/Minus** keys set the amount of time you want the vent valve to remain closed between each vent pulse.

5. Press the **Up Arrow** key to return to normal operation mode.

5.4.2 Setting the Parameters for the Optional Settings

Important Note: These settings will only function if the options they pertain to were purchased.

Refer to figure 6 below to help you complete these settings.

Figure 6

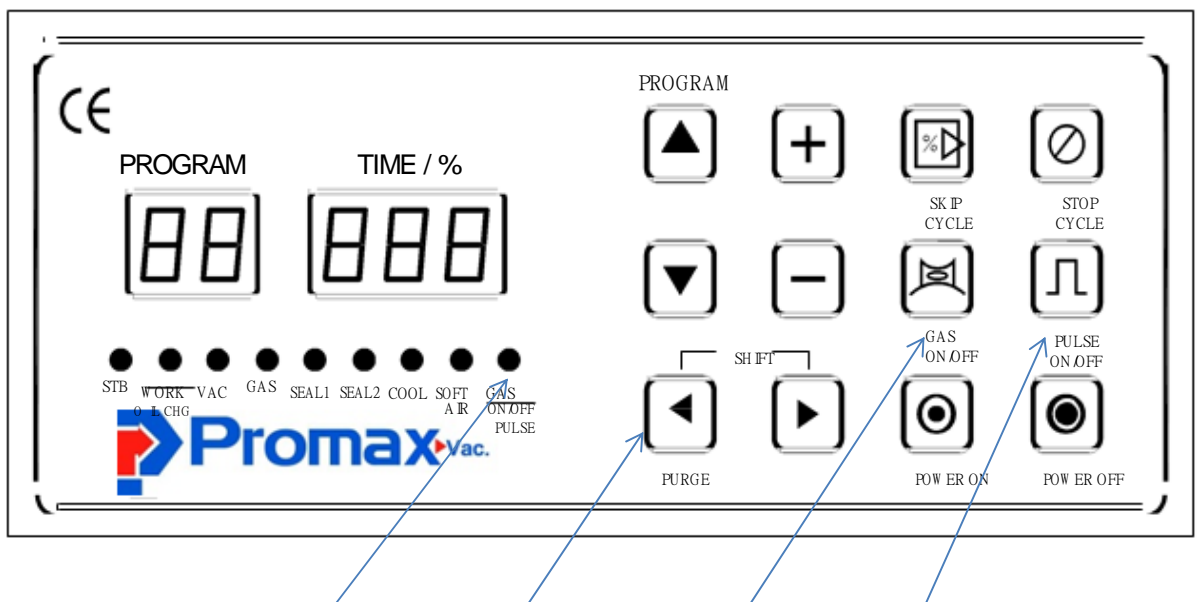

Gas On / Off / Pulse LED

Purge

Gas On / Off Pulse On / Off

A. Gas Flush

1. Prepare to make changes as instructed in point D
2. Press the **Left Arrow** key until the **Gas LED** is lit.
3. Using the **Plus / Minus** keys set the amount of time you want gas to enter the chamber.

4. Press the **Left Arrow** key again you will see that the **Gas LED** remains lit. You will set a time value for the next two settings **only if you wish to use the PULSE GAS feature.**
5. Using the **Plus / Minus** keys set a **GAS ON** time
6. Press the **Left Arrow** key to move to the **GAS OFF** time setting.
7. Using the **Plus / Minus** keys set a **Gas Off** time.
8. Press the **Left Arrow** key to move to the next setting.

Important Note: Once you have returned the control to the normal operation mode you **MUST** turn the GAS Feature and the PULSE feature on for them to become part of the cycle. To do this Press the **Gas On / Off** key, indicated in **Figure 6** above. The **Gas On / Off / Pulse LED** will light up. This indicates that the gas flush system is engaged.

If you wish to engage the **PULSE** feature you must Press the **PULSE On/Off** touchpad indicated in **Figure 6** (on the previous page). The **Gas On / Off LED** will begin to blink. The gas pulse feature is now engaged.

B. Vacuum by Percentage: This option allows your machine to control the amount of vacuum achieved as a function of vacuum pressure instead of being time based. **Your machine must be equipped with the optional Sensor Control for this option to be used.**

1. Enter the Edit Mode (follow the instructions in point D on Pg.00)
2. Make sure the LED above the word VAC is on.
3. Press the **Minus** key repeatedly until you pass **-1**. You will see the Time / Percent display change to **99**.
4. Continue to Press the **Minus** key until you have reached the vacuum percentage you desire..
5. Press the **Left Arrow** key to move to the next setting.

C. Percentage + Time Vacuum: This setting will allow your machine to reach 99% then continue to vacuum for a set amount of time before moving to the next stage of the cycle.

1. Follow the instructions above to the point where the number 99 has appeared in the Time / Percent display.
2. Press the **Plus** key and you will see a 1 with what looks like a sideways T next to it appear.
3. Continue to Press the **Plus** key until you have set the amount of time you want the vacuum to continue after 99% has been achieved.
4. Press the **Left** arrow key to move to the next setting.

D. Pulse Vacuum: This feature allows you to set the vacuum to pulse on and off for a preset **Total Vacuum Time**. If this optional feature has been purchased you will notice that the VAC setting will require three (3) settings to complete.

1. The first setting will be **Total Vacuum Time**. Using the **Plus/Minus** keys set the total time you want the vacuum cycle to last.
2. Press the **Right Arrow** key to move to the next setting. The VAC LED will remain on. However you are now setting the **Vacuum On Time**.
3. Using the **Plus/Minus** keys set the amount of time you want each vacuum pulse to last.
4. Press the **Right Arrow** key to move to the next setting.
5. Using the **Plus/Minus** keys set the amount of time you want the vacuum to remain off between each vacuum pulse.
6. You have now completed setting for a Pulsed Vacuum.
7. Press the **Right Arrow** key to move to your next setting.

E. Multi Stage Vacuum / Gas: This function allows your machine to perform multiple vacuum and gas stages before moving onto the seal mode. Up to 10 vacuum / gas or gas / vacuum stages may be set.

1. With the machine in the normal operation mode Press the Purge key indicated in Figure 6. You will see a decimal point appear in the **Program Display**. The machine can now be set for multi-stage operations that begin with a Vacuum cycle. If you Press the Purge key once more the decimal point will begin to blink. The machine will now perform multi-stage functions beginning with Gas. **Note: The vacuum will engage for 2 seconds to hold the lid down before the first gas stage begins.**
2. Once you have engaged the Purge function then enter EDIT MODE (follow the instructions indicated in point D on page 00).
3. The **VAC LED** will be lit and you will see a number appear in the **Time / Percentage** display. This number indicates how many stages you wish to execute.
4. Press the Plus / Minus keys to set the number of stages you want.
5. Press the **Left Arrow** key. You will see that the LED above the word **VAC** stays on.
6. Press the Plus / Minus Key to set the amount of Vacuum time for all of the vacuum stages. **This second setting is ALWAYS the vacuum time.**
7. Press the Left arrow key. You will see that the LED above the work **VAC** remains on.
8. Using the Plus / Minus keys set the amount of Gas time for all gas cycles. Note: **This third setting is always the Gas time.**

Note: If you Press the Purge key a third time the decimal point will disappear. The Purge function is now OFF and your regular Vacuum & Gas settings will resume.

6.MAINTENANCE

6.1 Basic Maintenance

The following maintenance procedures should be followed no matter what model Promarks machine you own.

6.1.1 Daily Visual Inspection

Your machine should have the following items inspected daily. If this inspection is performed daily prior to the start of your days production you will find that your machine will always perform consistently, last longer and suffer less down time.

A. Teflon Covers

1. Clean if they have any foreign mater adhering to them
2. Look for any burned spots, cuts or tears. Replace if needed.

B. Vacuum Pump Oil

1. Check the oil level. Fill if below Minimum on the sight gauge. Refer to Fig. 1 on page 6.
2. Replace the oil after 500 hours of operating time.

C. Vacuum Chamber Lid Gasket

1. Check for general wear
2. Check for damage
3. Replace as needed.

D. **Pressure Bar Rubber:** On TC and some SC machines this is the rubber part found in the lid of your machine that meets with the seal bar when the machine is in operation. In other SC machines and in all DC machines this is the rubber part that is located on the chamber's base that meets with the seal bar when the machine is in operation.

- 1 Check for excessive wear.
2. Check for burnt spots, cuts and tears.
3. Replace as needed.

E. Vacuum Pump Motor Sound

1. Listen for the smooth, normal sound of your vacuum pump.
2. If any abnormal sounds are detected **TURN OFF YOUR MACHINE RIGHT AWAY** and perform a trouble shooting procedure.

6.1.2 Daily cleaning

Important Note: The following daily cleaning points are meant to help keep your machine in proper working order. They are in no way intended to provide the required level of sanitation needed for the packaging of food products. As noted earlier in this manual your company should consult with an expert in the sanitation field to design a robust sanitation routine when packaging food products.

1. Clean the seal bar's Teflon tape very carefully using a rag and a mild organic solvent. **DO NOT** directly wash down this area of the machine.
2. Clean the rubber pad in the seal pressure bar. Once again use a rag and a mild organic solvent. **DO NOT** directly wash down this area of the machine.
3. Wipe down the stainless steel housing using an approved stainless steel cleaner.
4. On machines with clear chamber lids or viewing windows clean them using a mild glass cleaner.
5. If your machine is an SC Series or a DC Series unit open the housing access door and visually check for oil or debris around the vacuum pump area. If you see anything that needs to be cleaned **DO NOT start cleaning until the machine is properly locked out and tagged out.**

6.2 VACUUM PUMP MAINTENANCE

For detailed information concerning maintenance and repair of your machine's vacuum pump please refer to the manufactures operating manual that was packaged with your new machine.

6.3 SEAL BAR MAINTENANCE

A. Replacing the Teflon Cover

1. Remove the seal bars from your machine.
 - a. Seal bars are located in the chamber on all TC Series machines and some smaller SC Series machines.

- b. Seal bars are located in the lid on larger SC Series machines and all DC Series machines.
2. Remove the screws that hold the Teflon holding strap in place. Refer to **Figure A on the next page.**
 3. Remove the old Teflon cover.
 4. Inspect the seal element.
 - a. Clean it off with lacquer thinner if needed.
 - b. Replace if broken or burnt badly. **Refer to the instructions under B below for replacement**
 5. Install the new Teflon cover and reinstall the seal bars.

B. Replacing the Seal Element

1. Using a hex wrench loosen the screws holding the seal element and remove it
2. Install the new seal element. **Refer to Figures B & C on the next page.**
 - a. Place the new element across the surface of the seal bar leave an excess of about 3/4” at each end.
 - b. Make sure you put the tension spring back in place.

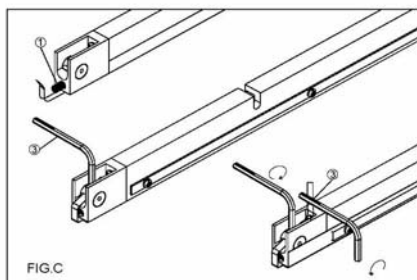
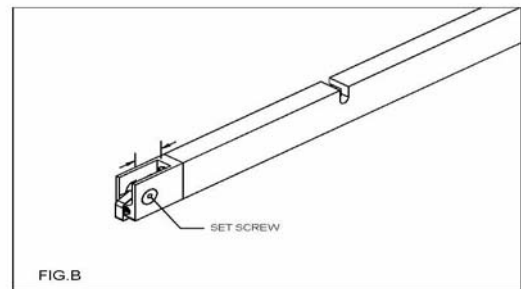
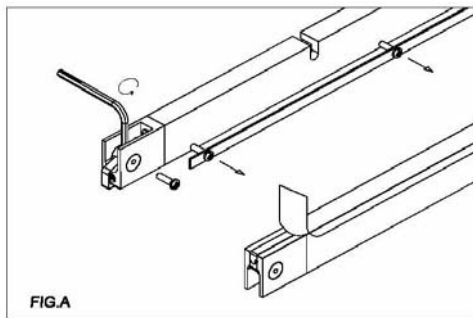

6.4 MAINTENANCE INTERVALS AND CHECK ITEMS

Maintenance Intervals/ Check items	Daily	Bimonthly	Quarterly	Yearly	Biyearly	3 ~ 5 years	Note
Keep the vacuum lid open after finished working and let vacuum pump running about 15 minutes.	X						
Check the oil level	X						
Check the sound of motor	X						
Oil come out from exhaust cover or not	X						
Bottom sealing bar working normally or not	X						
Clean the exhaust filter		X					
Change vacuum oil		X					
Replace exhaust filter				X			
Replace Teflon tape				X			As request
Replace sealing Silicone rubber				X			As request
Replace lid gasket rubber				X			As request
Replace pressure bag					X		As request
Replace vanes						X	

Above-mentioned maintenance intervals are scheduled basically for 8 working hours per day.

Recommended oil : A. Grav. API 30.5
 Pour Pt. -15°C
 Flash Pt. 225°C
 Viscosity 32.05 CST@40°C
 Color Light Yellow
 V.I. 100

7. TROUBLESHOOTING

7.1 PROBLEMS AND CORRECTIONS

Problem and Corrections - Review installation procedure section to ensure the installation is correct. If correct, the troubleshooting chart below lists possible problems, causes, corrections, and reference guide.

Problem	Cause	Correction
Control panel is under normal function, but vacuum pump does not start.	The KM1, QM1, MCB1, MCB2 protectors are disconnected.	Check each part and turn on the switch, reconnect, if necessary.
Vacuum pump does not run.	The power supply is not corresponding with the power demand indicated on the back of machine.	Reconnect to correct power source.
Insufficient vacuum in chamber.	Low oil level in vacuum pump. Lid silicone rubber damaged.	Fill oil, if necessary. Stop machine immediately. Then alter the power connection and reconnect to correct ones. Replace.
Insufficient vacuum in bag. Note : Mostly insufficient vacuum in bag is due to leakage of bag, but not the fault of machine.	Bag is leaking. Sharp corners on wrapped product puncture the bag. Bag is too large.	Replace the bag. Replace the bag and use a thicker one. Replace with a smaller one.
Vacuum bag is easily pulled apart by hand.	Sealing time (temperature) is too short (low).	Adjust sealing time (temperature) to be longer (higher).
Sealing area has some burnt marks or bubbles appeared.	Sealing area stuffed with oil or meat juice or dirt. Sealing time (temperature) is too long (high).	Clean and remove them. Adjust sealing time (temperature) to be shorter (lower).
Lid does not open.	Vacuum valve is damaged.	Replace it.

Problem	Cause	Correction
No or improper sealing.	Sealing wire is broken.	Replace it.
	Sealing wire is loose.	Tighten it.
	Insufficient pressure.	Pressure bar is damaged, replace it.
	Sealing transformer is damaged.	Replace it.
	Teflon tape or silicone rubber is damaged.	Replace it.
	Sealing time and cooling time are too short.	Adjust to proper time.
NOTE : Please do not adjust sealing longer than regular time, or it will reduce the life of Teflon tape and silicone rubber.	Sealing pressure is too low.	Replace the pressure bag.
	Lid does not close.	
	Vacuum valve is damaged.	Replace it.
	Limit switch is disconnected or damaged.	Reconnect or replace it.

7.2 25PIN D Type Terminal Wiring Connection Instructions

PIN NO	FUNCTION		PIN NO	FUNCTION	
1	AC24V Input — For Internal		13	External DC24V	Rectificated
2	AC24V Input — For Internal		14	External DC24V	Rectificated
3	AC24V Input — For External		15	Sealing Bar 2 Heat Contact	Relay Contact
4	AC24V Input — For External		16	Pulse Soft Air Contact	Relay Contact
5	Air Inlet Valve	Relay Contact	17	x	
6	Sealing Press Bar Gas Flushing	Relay Contact	18	x	
7	Sealing Bar 1 Heat	Relay Contact	19	x	
8	External Special Gas Valve	Relay Contact	20	x	
9	Vacuum Valve	Relay Contact	21	Over Relay Input Same As 25	External Input
10	COM	Relay Contact	22	Internal Grounding	External Input
11	Internal Grounding	External Input	23	COM point	Relay Contact
12	Vacuum Lid Signal Input	External Input	24	Vacuum Motor Contact	Relay Contact
			25	Over Relay Input Same As 21	External Input

7.2 PNEUMATIC DIAGRAM

NO	DESCR	QTY	NOTE
1	Vacuum gauge	1	
2	Control panel	1	
3	Pressure control valve	2	
4	Gas valve	2	
5	Vacuum pump	1	
6	Distributing connector	1	
7	Reservoir air	1	
8	Valve	1	
9	Valve	1	

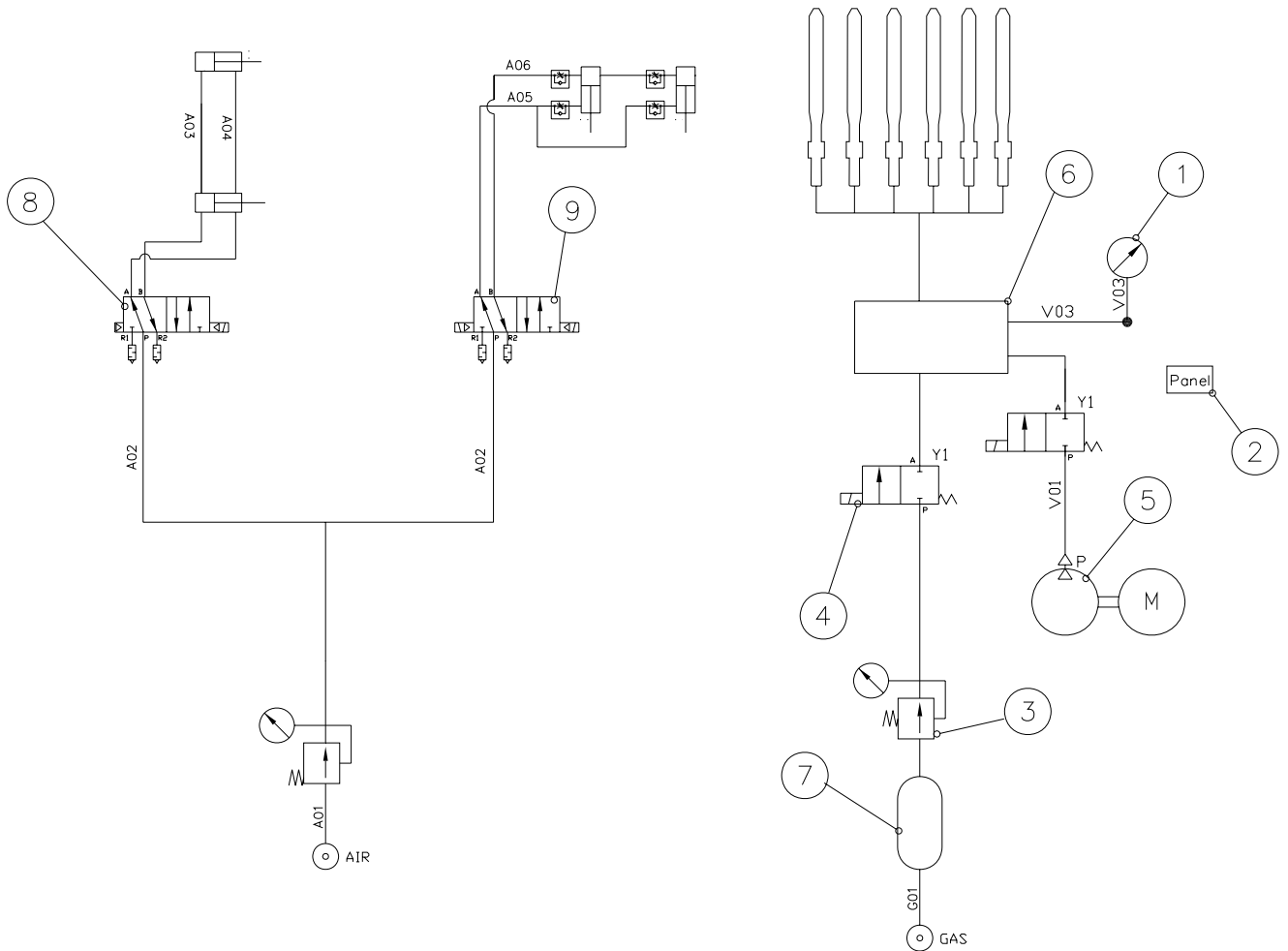

7.3 ELECTRICAL DIAGRAM

Electrical diagram
 Biactive seal
 PNC-01 Standard

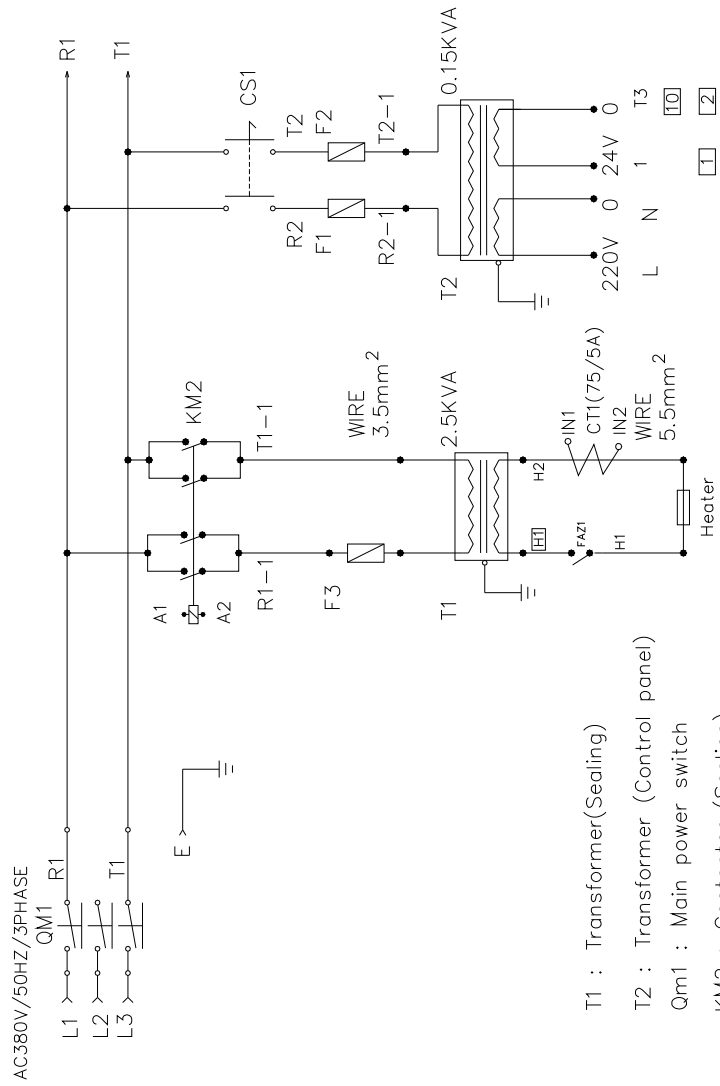

- T1 : Transformer(Sealing)
- T2 : Transformer (Control panel)
- Qm1 : Main power switch
- KM2 : Contactor (Sealing)
- F1(1A),F2(1A) : Fuse (Control panel)
- F3(25A) : Fuse (Sealing transformer) (200~240V) or 110V
- F3(15A) : Fuse (Sealing transformer) (380~480V)
- FAZ1 : FAZ-C32/1
- CS1 : Power switch

Proposed Plug And Socket	25P D-SUB	Terminal	Wire Color
1	352	0	Black
2	T3	0	Brown
3			
4			
5	16	0	Yellow
6	12	0	Green
7	29	0	Blue
8	32	0	Purple
9	4	0	Grey
10	352	0	White
11	14	0	Pink
12	15	0	Light green
13			
14			
15			
16			
17			
18			
19			
20			
21			
22	59	0	White/black
23			
24			
25	60	0	Light blue/black

7.4 ELECTRICAL DIAGRAM

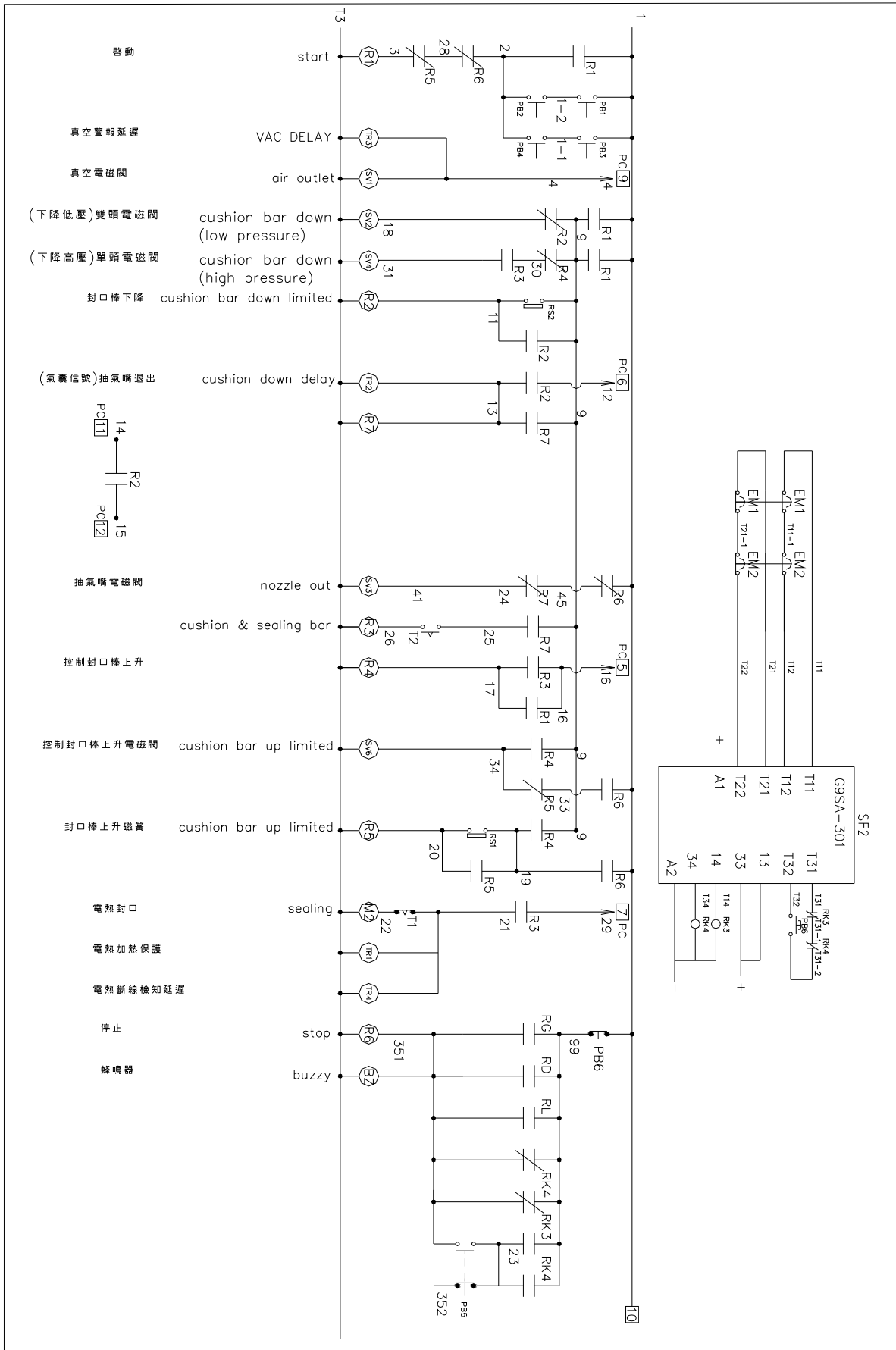

8. FABRICATION

8.1 FRONT SIDE DIAGRAM

8.3 ELECTRICAL BOX

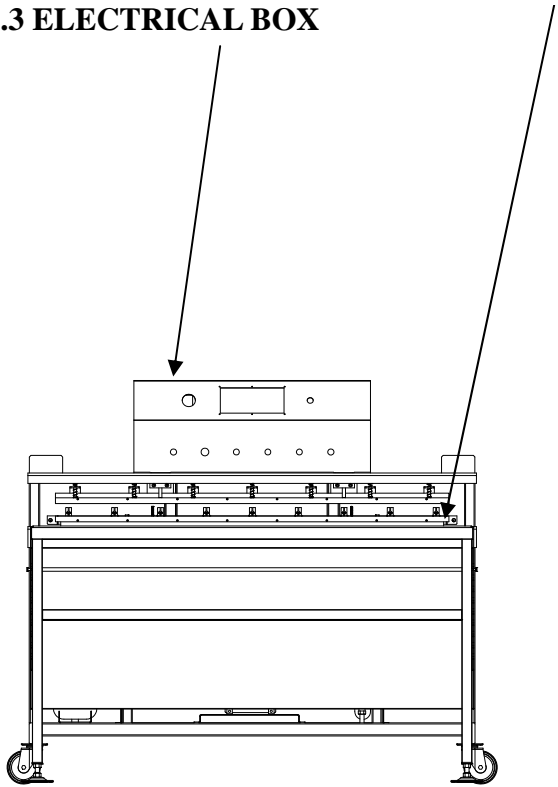

8.2 AFTER SIDE DIAGRAM

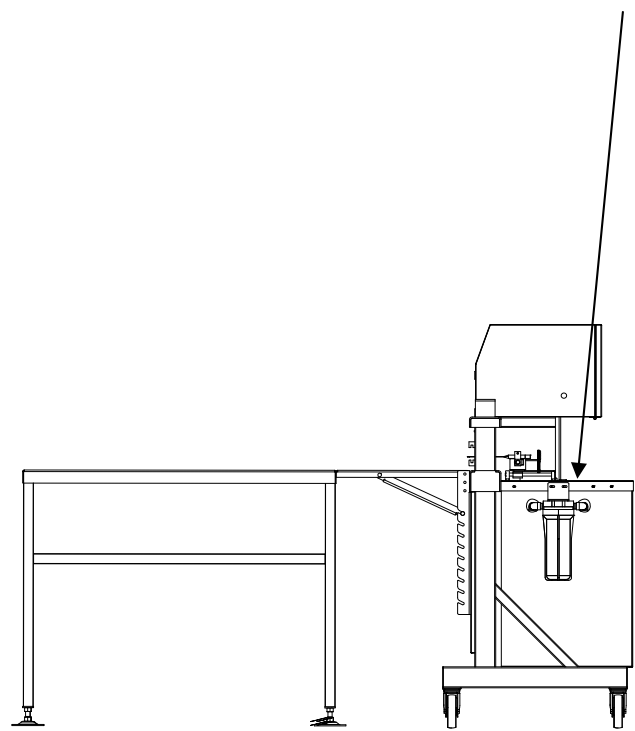

8.1 FRONT SIDE DIAGRAM

Front side Diagram

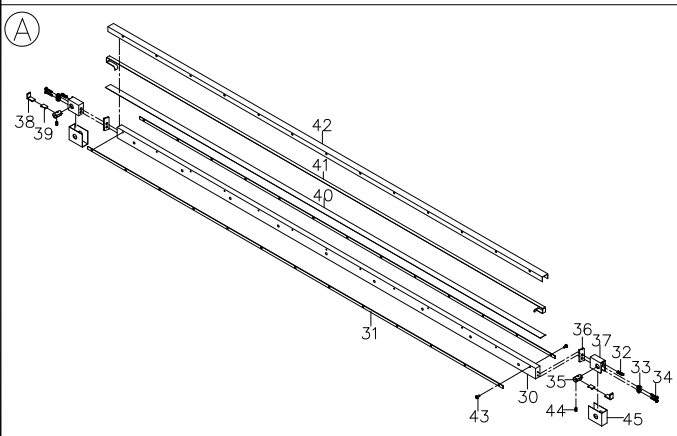
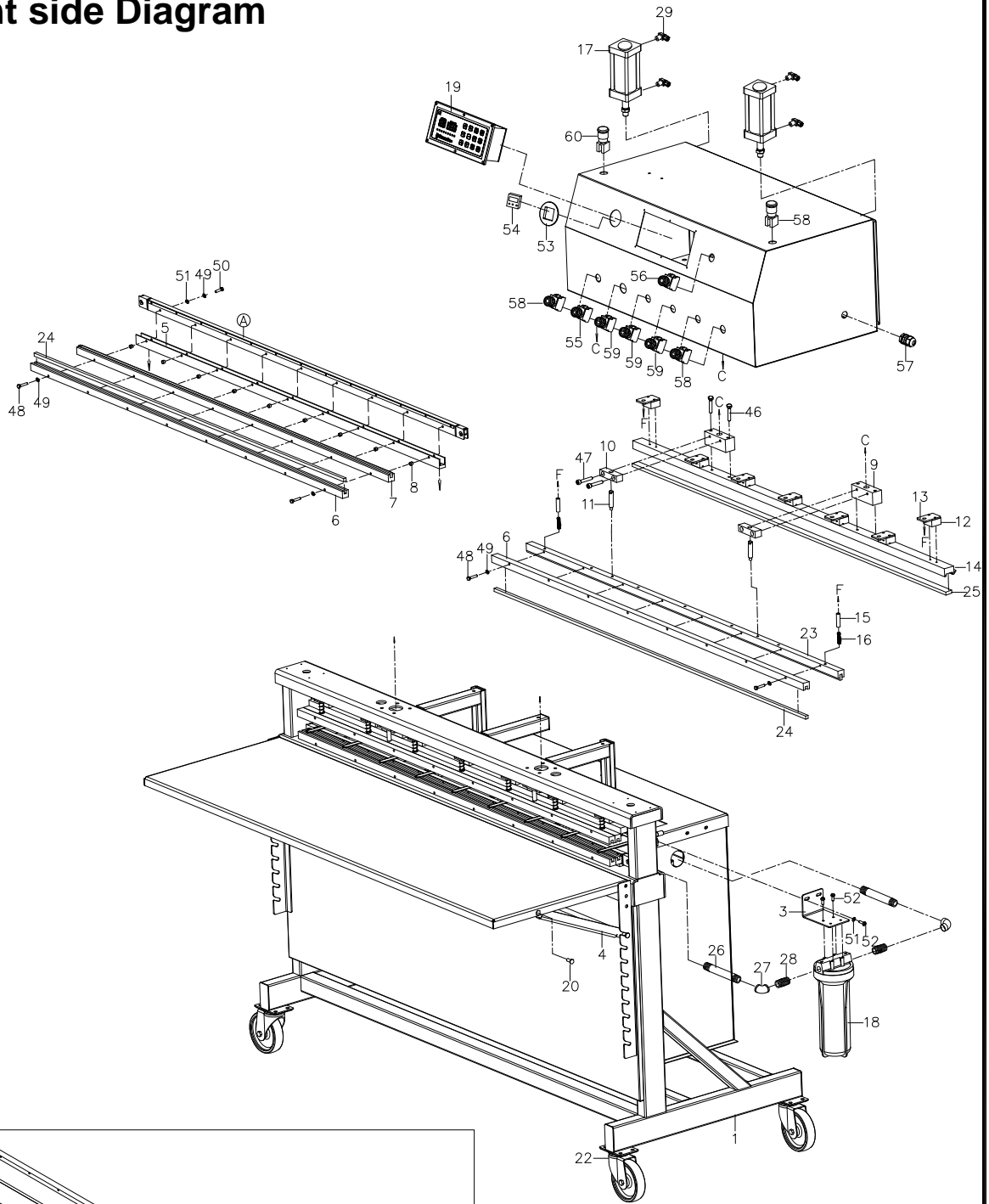

NZ1500000

8.1 FRONT SIDE DIAGRAM

Working table Diagram

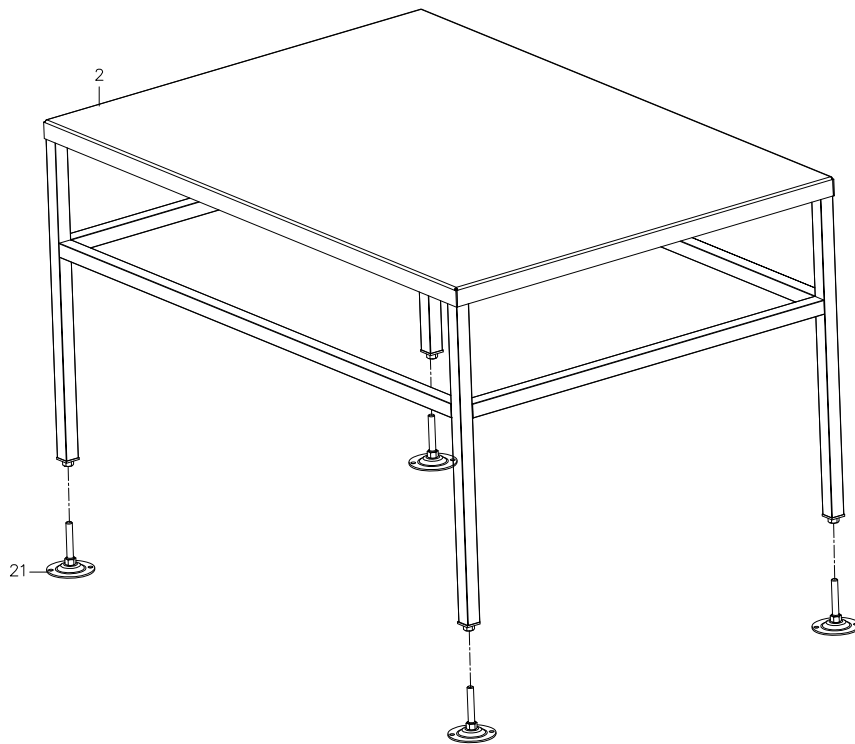

NZ15000000

NO.	PART NO.	DESCRIPTION	QTY	NOTES
1	188074A1	Frame	1	
2	188074A2	Working table	1	
3	NZ10113000	Fixed plate	1	
4	NZ15105000	Support plate	1	
5	NZ15114000	Holder-sealing bar	1	
6	NZ15115000	Front compression mount	2	
7	NZ15116000	Front compression mount	1	
8	NZ10127000	Bushing	9	
9	NZ10130000	Top sealing bar fixed mount	2	
10	NZ10137000	Guide block	2	
11	NZ10138000	Pin	2	
12	NZ10140000	Interval block	7	
13	NZ10139000	Spring support plate	7	
14	NZ15118000	Sealing bar-top	1	
15	NZ10133000	Bushing	7	
16	NZ10136000	Spring	7	
17	2920675	Cylinder MCQA-11-63-75M	2	
18	2940001	Filter bottle	1	
19	2874033	Control panel	1	
20	17101322	Bolt	2	
21	BMX8106000	Base leg	4	
22	27121181	Casters	4	
23	NZ15121000	Top compression mount	1	
24	27400356	Silicon foam	2	
25	NZ15132000	Sealing silicon	1	
26	29093279	Nipple 1/2"	2	
27	27400066S	Elbow 1/2"	4	
28	29093278	Nipple 1/2"	2	
29	29080171	Fitting JSC 8-03	2	
30	NZ15112000	Sealing bar	1	
31	NZ15113000	Teflon tape plate	2	
32	VA04277000	Compression spring	2	
33	D80K317000	Isolated sleeve	4	
34	2703308	Round head screw M4x12	4	
35	D80K316000	Connecting copper shaft	2	

NO.	PART NO.	DESCRIPTION	QTY	NOTES
36	D80K314000	Isolated flat plate	2	
37	D80K315001	Copper connector sealing	2	
38	D80K375000	Spring fixed plate	2	
39	D80K377000	Lining plate	2	
40	S022102	Teflon tape	1	
41	282411115	Sealing wire	1	
42	3200953-3	Teflon tape	1	
43	2703325	Round screw hd M4x8	26	
44	2704603	Socket set screw M6x10	2	
45	3200955	Teflon tape	2	
46	27004202	Hex head screw M8x50	4	
47	2701173	Socket set screw M8x25	4	
48	2700462	Hex head screw M6 x30	12	
49	2705302	Split lock washer M6	24	
50	2700440	Hex head screw M6 x35	21	
51	2705151	Flat washer M6	21	
52	2701331	Round screw hd M6x20	6	
53	18807410	Plug	1	
54	2961013	Pressure switch	1	
55	2890132	Buzzer	1	
56	2871220	Switch selector	1	
57	2861021	Fitting MG-20A-14B	1	
58	2870049	Switch on/off return	3	
	28704940	Rubber button zbpo	3	
59	2871740	Indicator lamp white	3	
	2871748	Body indicator lamp	3	
	28704984	Bulb Lamp	3	
60	2870049	Switch on/off return	1	
	28704940	Rubber button zbpo	1	
	28700291	Contact green	1	
A	NZ15134A00	Sealing bar assembly	1	

8.2 AFTER SIDE DIAGRAM

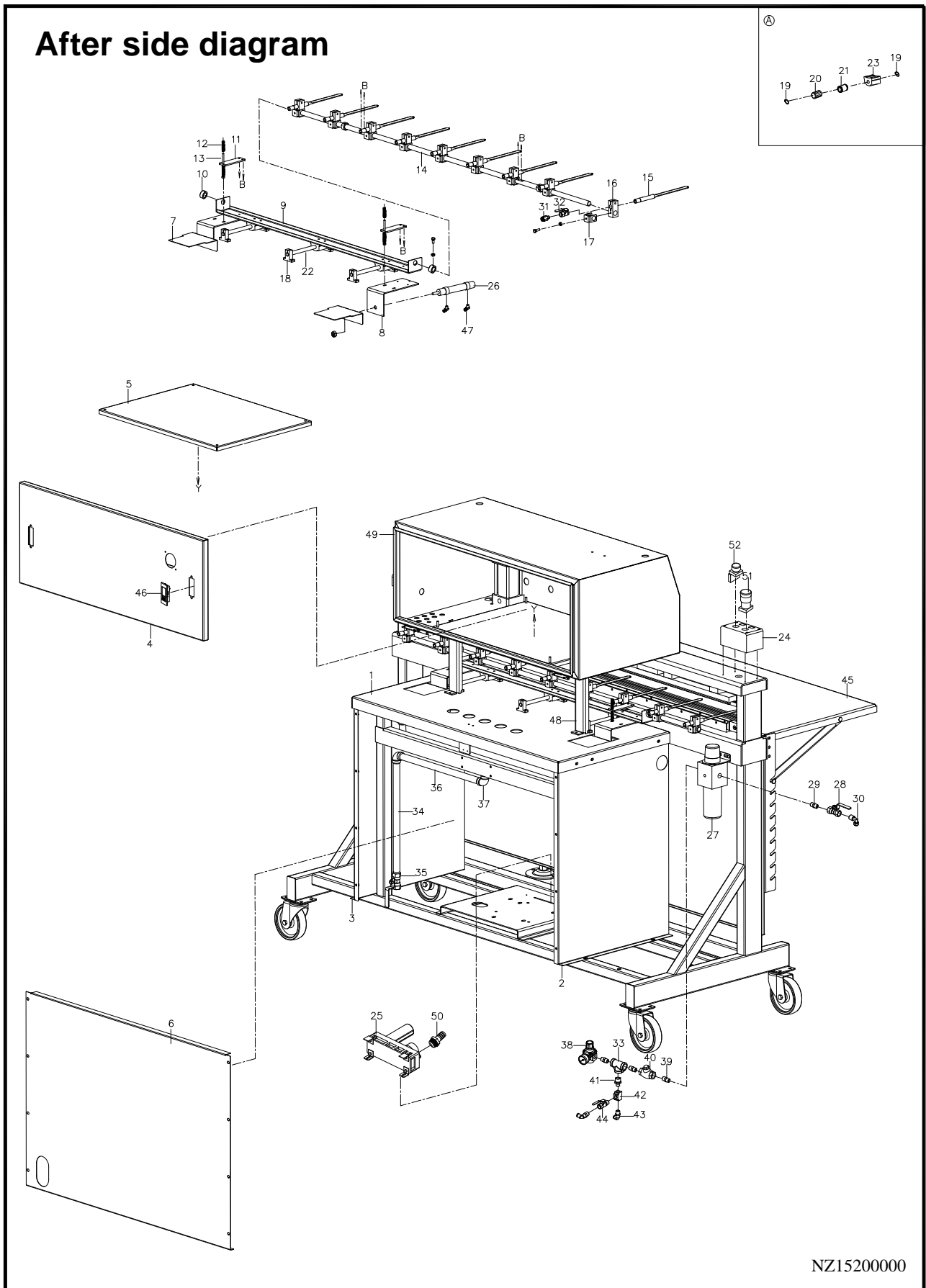

NZ15200000

NO.	PART NO.	DESCRIPTION	QTY	NOTES
1	NZ15103000	Cover plate	1	
2	NZ10109000	Left side plate	1	
3	NZ10110000	Right side plate	1	
4	NZ15806000	Plate	1	
5	NZ15804000	Panel	1	
6	NZ15106000	Back cover plate	1	
7	18807403	Cover plate	2	
8	NZ10114000	Cylinder rod fixed plate	2	
9	NZ15111000	Push plate	1	
10	NZ10120000	Fixed block	2	
11	NZ10135000	Spring fixed plate	2	
12	NZ10115000	Spring	4	
13	NZ15120000	Shaft fixed spring	2	
14	NZ15119000	Support rod	1	
15	NZ10122001	Vacuum suck	8	
16	NZ10121000	Suck fixed mount	8	
17	NZ10145000	Fixed mount	8	
18	2728137	Shaft fixed mount	3	
19	27062210	Ring R21	6	
20	27281047	Slide bushing	3	
21	NZ10118010	Bearing bush	3	
22	NZ10117000	Guide shaft	3	
23	27281048	Bearing mount	3	
24	2873134	Box	2	
25	2930033	Generator vacuum	1	
26	29232101	Cylinder MCMA-11-25-100N	2	
27	29119056	Regulator AW40-04BD-A	1	
28	29099231	Fitting 1/2"	1	
29	29093282	Fitting 1/2"	2	
30	29093432	Fitting A036-2	1	
31	29090429	Fitting A-015 1/4"x5/16"	12	
32	2909501	Fitting 1/4"	8	
33	29090097	Tee branch 1/2"	1	
34	NZ10148000	Fitting	1	
35	2961098	Fitting 1/2"	1	

NO.	PART NO.	DESCRIPTION	QTY	NOTES
36	NZ15108000	Fitting	1	
37	27400066S	Elbow 1/2"	6	
38	29100052	Regulator AR20-02H-B	1	
39	2909116	Fitting 1/2"x1/2"	2	
40	2920231	Valve check 1/2"	1	
41	2909115	Fitting copper 1/2"x1/4"	2	
42	2909009	Fitting P86-1 1/4"	1	
43	2909328	Fitting SPL 6-02	2	
44	2909511	Fitting 1/4"	1	
45	NZ15135001	Working table	1	
46	2883134	Latch door	2	
47	2908016	Fitting JSC8-01	2	
48	NZ15133000	Fixed plate	2	
49	NZ15805000	Control box	1	
50	RS4A11A000	Fitting	1	
51	2834053	Switch emergency	2	
52	2870049	Switch on/off return	2	
	28704940	Rubber button zbpo	2	
A	NZ10118000	Bearing linear	3	

8.3 ELECTRICAL BOX(FB)

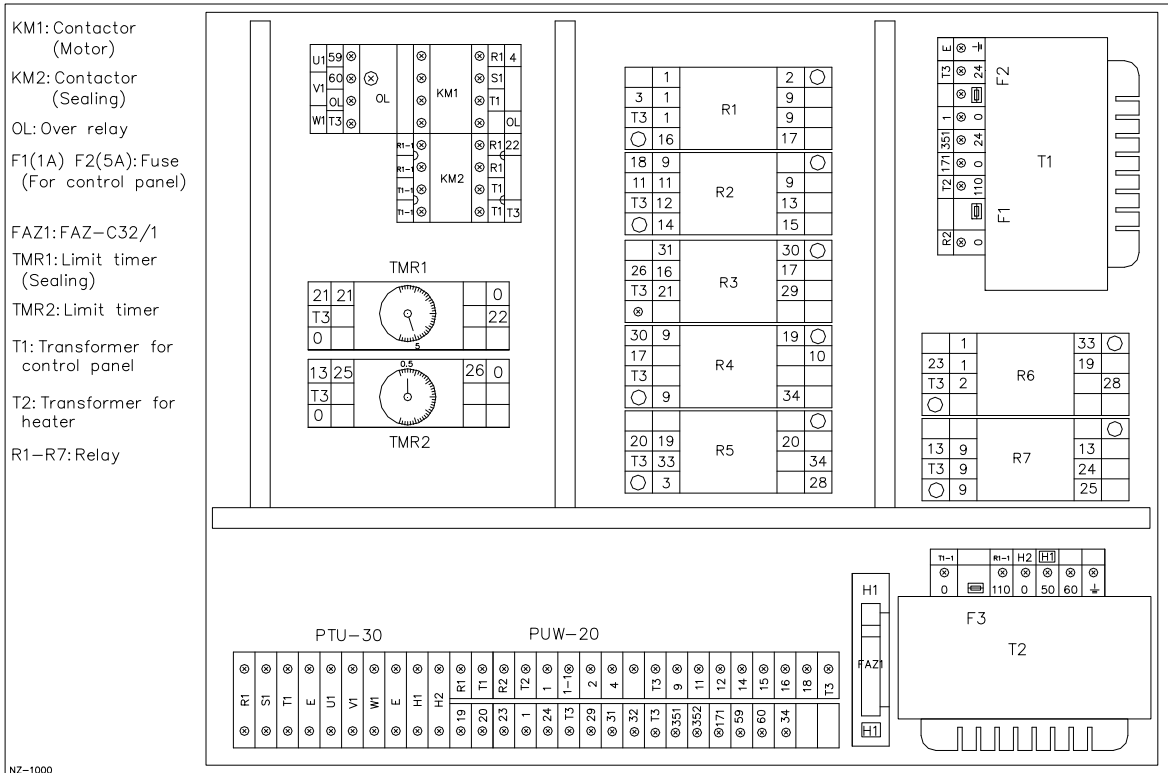

NZ-1000

ITEM	PART NO.	DESCRIPTION	SPECIFICATION	Q'TY	NOTE
KM1	28107281	Contactor	CU-11-B5	1	
KM2	2810758		CU-18		
OL	2811514	Overload Relay	RHN-10K(12.5-18A)	1	
PTU-30	2843209	TERMINAL	PTU-30	10	
PUW-20	2843204	TERMINAL	PUW-20	18	
R1~7	2830132	Relay	RU4S-C-A24	1	
	2831106	Socket, Relay	SY4S-05D	1	
	2850636	Hook	PYC-A1	2	
F1	2890048	Fuse	20mm 1A	1	
F2	2890046	Fuse	20mm 5A	1	
F3	2890069	Fuse	20mm 25A	1	
FAZ	2801734	Breaker	FAZ-C32/1	1	
TMR1~2	2833328	Time Relay	ANLY AMY-2 6S AC24V	1	
	2833329	Socket Relay	PYF08A-E MY2	1	
	2850635	Hook	FM-4	2	
T1	28960663	Transformer TBSW-1I-120VA	0F-110V/0-24V	1	
T2	28961467	Transformer TBSW-1I-700VA	0F-110/0-50-60 CE	1	