



SC-520

**Single Chamber Vacuum Packaging
Machine**

Operation Manual

Version 6.9.1

1915 E. Acacia Street, Ontario, CA91761, U.S.A

TEL : 1-909-923-3888

FAX : 1-909-923-3588

<http://www.promarksvac.com>

S/N:

QC SIGNATURE:

TABLE OF CONTENTS

1. SAFETY	1
1.1 SAFETY RECOMMENDATIONS	1
1.2 PERSONAL SAFETY	2
1.3 FOOD SAFETY	3
2. INSTALLATION	4
2.1 UNPACKING	4
2.2 MOVING THE MACHINE	4
2.3 MACHINE SPECIFICATIONS	5
2.4 ENVIRONMENT REQUIREMENTS	5
2.5 CHECK OIL LEVEL	6
2.6 POWER CONNECTION	6
2.7 VACUUM PUMP ROTATION	6
3. OPERATION	7
3.1 VACUUM SETTING GUIDELINES	7
3.2 BASIC OPERATING INSTRUCTIONS	7
3.3 OPTIONAL DEVICE	7
3.3.1 GAS FLUSHING UNIT	7
3.4 OPERATION OF THE PA-01 ANALOG CONTROL PANEL	8
4. MAINTENANCE	9
4.1 BASIC MAINTENANCE	9
4.1.1 DAILY VISUAL INSPECTION	9
4.1.2 DAILY CLEANING	9
4.2 VACUUM PUMP MAINTENANCE	10
4.3 SEAL BAR MAINTENANCE	10-11
4.4 MAINTENANCE INTERVAL CHART	12
5. TROUBLESHOOTING	13
5.1 PROBLEMS AND CORRECTIONS	13-14
6. DRAWINGS	15
6.1 PNEUMATIC DIAGRAM	15
6.2 ELECTRICAL DIAGRAM	16
7. FABRICATION	17
7.1 BODY DIAGRAM	18-19
7.2 VACUUM CHAMBER DIAGRAMS	20
7.2.1 VACUUM CHAMBER DIAGRAM	20-22
7.2.2 VACUUM CHAMBER DIAGRAM	23-25
7.3 SEALING BAR CONFIGUATIONS	26
7.3.1 SEAL BAR DIAGRAM(FLR+C)	26-27
7.3.2 SEAL BAR DIAGRAM(FLR)	28-29
7.4 LID DIAGRAMS	30
7.4.1 LID DIAGRAM	30-31
7.4.2 LID DIAGRAM	32-33
7.5 ELECTRICAL BOX	34-35

Explanation of Abbreviations

(F) Front Seal

(LR) Left & Right Seal

(FC) Front Seal with Hot Wire Cut-off

(LRC) Left & Right Seal with Hot Wire Cut-off

General

This owner's manual contains information relating to your Promax/ Promarks machine. It will provide you with basic information concerning both operation and maintenance of your new machine. Please read it carefully as failure to do so may result in bodily injury and / or damage to the equipment.

Please fill in the information below. You will find the information on the bill of lading and on the machines identification tag. You will need this information when ordering replacement parts or making technical inquiries.

Model # _____

Serial # _____

Ship Date: _____

Owner: _____

Location: _____

1. SAFETY

1.1 SAFETY RECOMENDATIONS

Unsafe practices or unauthorized modifications of machine could result in accidents or property damage.

For safe installation, operation, handling and maintenance, please strictly follow the simple safety rules stated below and take precautions. Failure to follow these safety rules and take necessary precautions can result in serious injury or death as well as cause damage to the equipment.

- 1) Never operate or service your Promax / Promarks machine until you have read this manual completely and understand it fully.
- 2) All adjustments and repairs must be carried out only by qualified technicians or maintenance personnel.
- 3) No service work should be attempted until the machine's power has been turned off. All proper lock out / tag out procedures should be followed.
- 4) Do not put tools, parts or other foreign objects on or into the machine.
- 5) Always keep the machine clean, lubricated and in good working condition.
- 6) To provide protection against the risk of electrical shock the power connection must be properly grounded at all times.
- 7) The machine should always be operated on a flat stable surface.
- 8) A certified electrician should be employed to install the permanent electrical connections for your new machine.

1.2 PERSONAL SAFETY

Please read and understand this operation manual before using this equipment. Failure to follow the operating instructions may result in personal injury or damage to the machine.

The following procedures and guidelines must be observed to avoid problems that can result in property damage, personal injury or death. If you have any questions regarding this information please contact Promax /Promarks, Inc. Service Department at (909) 481-3338.

Hazardous Voltage: DANGER

Electrical power must be disconnected and locked out before servicing or cleaning of the machine. Do not remove any panels before power has been disconnected and locked out due to the risk of electric shock hazard.

Explosion Hazard: DANGER

When utilizing the gas flush feature (optional) do not use any gas mixture with greater than 22% oxygen content.

Blade Hazard: WARNING

If your machine is equipped with either a Perforating Knife System (optional) or a Precut Knife System (optional) then do not remove or install blades without wearing protective gloves. These blades are SHARP, use care when handling.

Signal words used in classifying potential hazards are defined as follows:

DANGER: Indicates an imminently hazardous situation, which if not avoided, may result in death or serious injury.

WARNING: Indicates a potentially hazardous situation, which if not avoided, could result in serious injury.

CAUTION: Indicates a potentially hazardous situation, which, if not avoided, may result in minor to moderate injury. Caution also indicates actions that may cause property damage.

1.3 FOOD SAFETY

While many Promax / Promarks machines are used in applications involving vacuum packaging and vacuum cooking, there are inherent risks associated with these techniques that can result in serious illness or death to the consumer of the food product. Therefore if you are using your machine for food applications, you must consult a qualified food technician or specialist in vacuum / modified atmosphere (M.A.P.) to review the safety of your application.

GAS FLUSH

If your machine is equipped with gas flush (optional) and your application involves the use of gas flush to extend the shelf life of your product you must consult a qualified food technician or specialist to review your application and develop a suitable gas mixture for your package. Further you must perform quality control and gas analysis on your final M.A.P. package.

CLEANING

Every environment and application is different; therefore Promax / Promarks cannot provide cleaning procedure instructions that will guarantee microbiological sanitation. Therefore Promax / Promarks recommends that the purchaser of these machines consult with a sanitation expert to review your procedures for cleaning the machine while operating in your environment and with your specific product to develop a robust cleaning schedule and methodology, followed by bacterial testing to ensure satisfactory cleaning is achieved.

2.INSTALLATION

2.1 UNPACKING

- Carefully remove the cardboard outer shell by cutting the retaining straps then removing the top and then the side panels.
- Inspect the machine carefully for any hidden shipping damage. Notify the shipping company right away if any damage is observed.
- Remove the machine from the wooden skid. This can be done by two people on the smaller table top machines. However an approved fork lift will be required for the larger SC and DC models. **Important note:** Refer to the Moving the Machine Section below.
- Wipe down the outside of the machine.

2.2 MOVING THE MACHINE

Promax chamber style vacuum packaging machines are available in three basic designs, TC (Table Top), SC (Free Standing Single Chamber) and DC (Double Chamber). Recommendations for the movement of all three types are listed below.

TC Machines: Some of the smallest TC units may be lifted off of their wooden skid and moved manually. However Promax recommends that moving even the smallest of their TC units should not be attempted by one person. The larger TC units should be lifted with the aid of a fork lift or other approved lifting aid. Prior to lifting with a forklift the forks should be adjusted to a width that provides the machine with stable support. The proper lifting point for TC machines is to place the forks so they come in contact with the units rubber feet located on the bottom of the machine.

SC Machines: All SC units should be lifted from their wooden skid and moved to the location where they will be used with an approved fork lift. Be sure to take note of the points listed below.

DC Machines: All DC units should be lifted from their wooden skid and moved to the location where they will be used with an approved fork lift. Be sure to take note of the points listed below.

*** Make sure the fork lift forks are properly adjusted for width and use fork extensions if needed.**

*** Make sure to ascertain the center of gravity and use identified lifting points.**

2.3 SC-520 SPECIFICATION

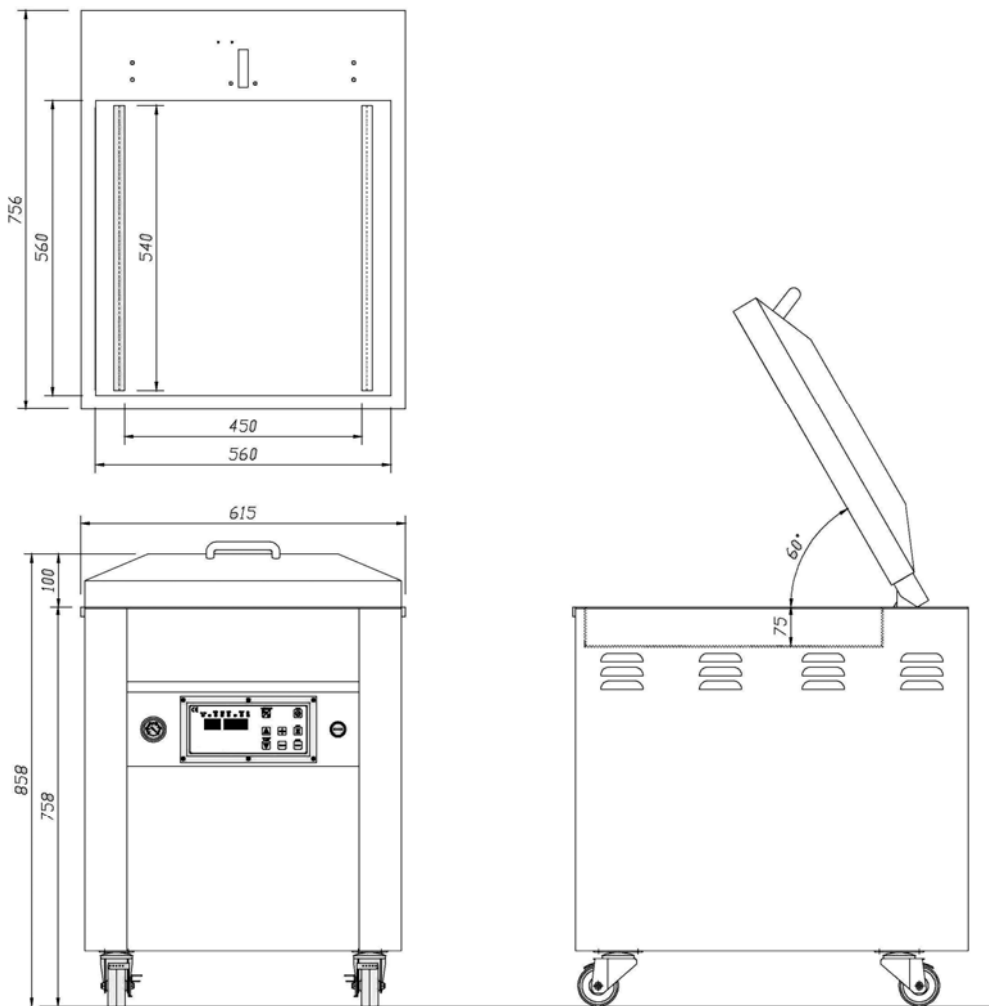

2.4 ENVIRONMENT REQUIREMENTS

The machine will be difficult to start if the air temperature is very low. This is caused by the increase in the vacuum pump's oil viscosity due to the low temperature. To prevent this, please set up machine according to the installation checklist described as below:

- Temperature: around 5 ~ 40°C
- Working elevation: between 0 ~ 1000 meters
- Relative humidity: 30 ~ 95% RH
- During operating, heat is generated by the vacuum pump and vacuum process, so a machine temperature of around 70 ~ 80°C is normal. The machine must have free air access for cooling.
- A minimum distance from walls, other machines, etc. should be maintained, at least 20 cm for each side of machine for providing adequate ventilation.

2.5 CHECK OIL LEVEL

Check the oil level only when the machine is not in operation and all vacuum built up in the chamber has been vented. Be aware that the oil may be very hot and avoid all contact.

Checking the Oil Level

- * Check the oil level on a daily basis
- * When checking the oil level use the sight gauge shown in **figure 1 below**. The level should be between the arrows indicating Minimum and Maximum. If the level is below the minimum arrow add oil until the maximum arrow is reached.

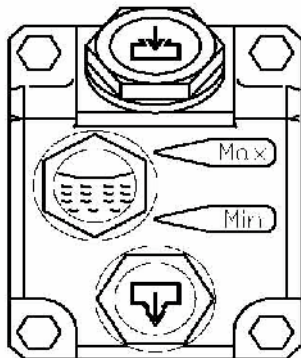

Figure 1

2.6 POWER CONNECTION

When preparing to install the machine's main power connection please refer to the electrical information on the serial number plate located on the machine's back panel. A certified electrician should be employed to complete this connection.

2.7 VACUUM PUMP ROTATION

If your machine operates on 3 phase power it is important to check the rotation of the vacuum pump. The pump should turn in the direction indicated in **Figure 2** below. If the pump turns in the wrong direction it will make a sound that is obviously wrong. Turn off the power immediately and change the position of two of the power wires and retest.

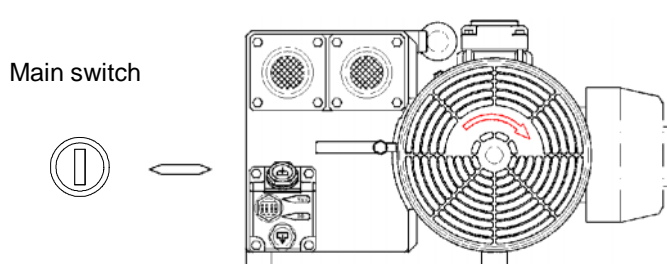

Figure 2

3. OPERATION

3.1 VACUUM SETTING GUIDLINES

Products	Vacuum time/Sec.	Storage life when stored at 2 ~ 6 °C/day
Fresh meat	30	10
Pork	30	10
Beef	30	30
Meat with liquid	15 ~ 30	14
Pasta	3 ~ 9	21
Sliced sausage	15	10
Cold cuts	9	10 ~ 21

3.2 BASIC OPERATING INSTRUCTIONS

Turn on the main switch and the LED display shows the operation menu, at this time, machine is ready to operate.

Place the product to be packaged in a vacuum pouch. Place the bag in chamber with the open end of bag across the sealing bar. (With a package that doesn't completely fill the chamber, place provided flat plates in the chamber to shorten vacuum time.)

Close the lid to start the cycle, the lid will open automatically when cycle is completed.

Take out the sealed product from vacuum chamber. You are ready to start the next cycle.

After all packaging is completed, please let the vacuum pump run for about 15 minutes, then turn off the main switch to shut down the machine.

3.3 OPTIONAL DEVICE

3.3.1 GAS FLUSHING UNIT

If your machine is equipped with an optional gas flush system please note the following points.

Make sure you have connected a regulated gas source to the gas inlet fitting

Do not set your regulator for a pressure of greater than 40psi

Place the open end of your package in front of the gas inlet nozzles

Do not tuck the bag under the gas nozzles

3.4 Operation of the Optional PD-01 Digital Control

Using the touch up/down touch pads (Refer to Fig. 4 below) set the time for the vacuum, gas , and seal and cool as indicated below. The times indicated in the digital display are in seconds.

Important note: the settings indicated below represent a starting point only and you will need to perform adequate testing to determine the exact settings needed for your product.

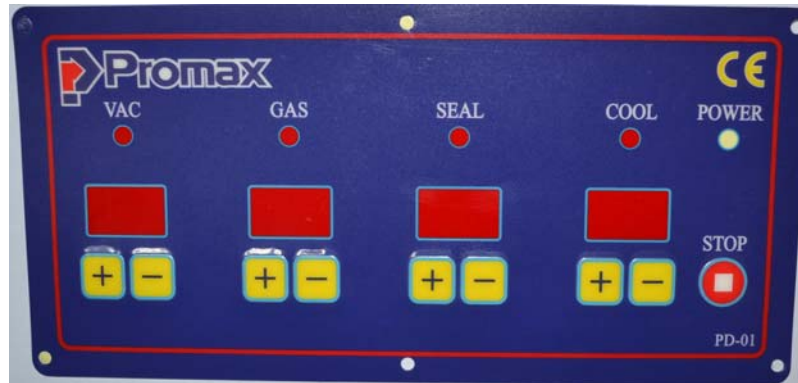

1. Vacuum: Set a time of 15 seconds

2. Gas Flush (optional): If your machine is equipped with a gas flush system set a time of 5 seconds. If your machine does not have a gas flush system or you will not use gas flush for the current application then it is very important to set a time of 0.0 seconds.

3. Seal: Set a time of 1.5 seconds.

4. Cool: Set a time of 3.0 seconds.

4. MAINTENANCE

4.1 Basic Maintenance

The following maintenance procedures should be followed no matter what model Promax/ Promarks machine you own.

4.1.1 Daily Visual Inspection

Your machine should have the following items inspected daily. If this inspection is performed daily prior to the start of your days production you will find that your machine will always perform consistently, last longer and suffer less down time.

A. Teflon Covers

1. Clean if they have any foreign mater adhering to them
2. Look for any burned spots, cuts or tears. Replace if needed.

B. Vacuum Pump Oil

1. Check the oil level. Fill if below Minimum on the sight gauge. Refer to Page 7.
- 2 . Replace the oil after 500 hours of operating time.

C. Vacuum Chamber Lid Gasket

1. Check for general wear
2. Check for damage
3. Replace as needed.

D. Pressure Bar Rubber: On TC and some SC machines this is the rubber part found in the lid of your machine that meets with the seal bar when the machine is in operation. In other SC machines and in all DC machines this is the rubber part that is located on the chamber's base that meets with the seal bar when the machine is in operation.

- 1 Check for excessive wear.
2. Check for burnt spots, cuts and tears.
3. Replace as needed.

E. Vacuum Pump Motor Sound

1. Listen for the smooth, normal sound of your vacuum pump.
2. If any abnormal sounds are detected **TURN OFF YOUR MACHINE RIGHT AWAY** and perform a trouble shooting procedure..

4.1.2 Daily Cleaning

Important Note: The following daily cleaning points are meant to help keep your machine in proper working order. They are in no way intended to provide the required level of sanitation needed for the packaging of food products. As noted earlier in this manual your company should consult with an expert in the sanitation field to design a robust sanitation routine when packaging food products.

1. Clean the seal bar's Teflon tape very carefully using a rag and a mild organic solvent. **DO NOT** directly wash down this area of the machine.
2. Clean the rubber pad in the seal pressure bar. Once again use a rag and a mild organic solvent. **DO NOT** directly wash down this area of the machine.
3. Wipe down the stainless steel housing using an approved stainless steel cleaner.
4. On machines with clear chamber lids or viewing windows clean them using a mild glass cleaner.
5. If your machine is an SC Series or a DC Series unit open the housing access door and visually check for oil or debris around the vacuum pump area. If you see anything that needs to be cleaned **DO NOT start cleaning until the machine is properly locked out and tagged out.**

4.2 Vacuum Pump Maintenance

For detailed information concerning maintenance and repair of your machine's vacuum pump please refer to the manufacturer's operating manual that was packaged with your new machine.

4.3 Seal Bar Maintenance

A. Replacing the Teflon Cover

1. Remove the seal bars from your machine.
 - a. Seal bars are located in the chamber on all TC Series machines and some smaller SC Series machines.
 - b. Seal bars are located in the lid on larger SC Series machines and all DC Series machines.
2. Remove the screws that hold the Teflon holding strap in place. Refer to **Figure A on the next page.**
3. Remove the old Teflon cover.
4. Inspect the seal element.
 - a. Clean it off with lacquer thinner if needed.
 - b. Replace if broken or burnt badly. **Refer to the instructions under B below for replacement**
5. Install the new Teflon cover and reinstall the seal bars.

B. Replacing the Seal Element

1. Using a hex wrench loosen the screws holding the seal element and remove it
2. Install the new seal element. **Refer to Figures B & C on the next page.**
 - a. Place the new element across the surface of the seal bar leave an excess of about 3/4" at each end.
 - b. Make sure you put the tension spring back in place..

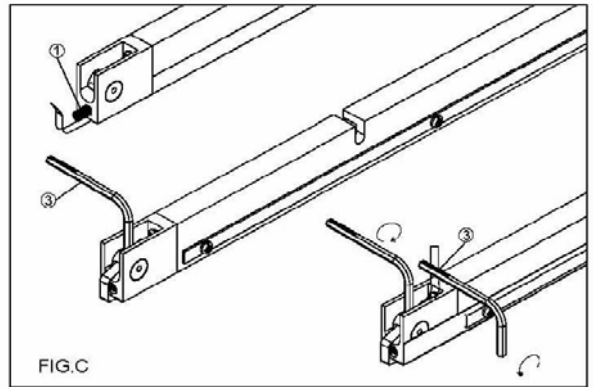
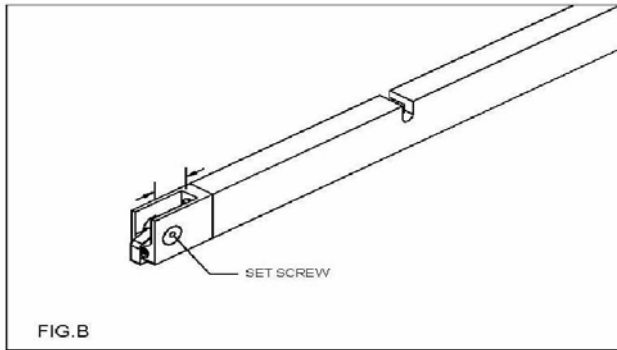
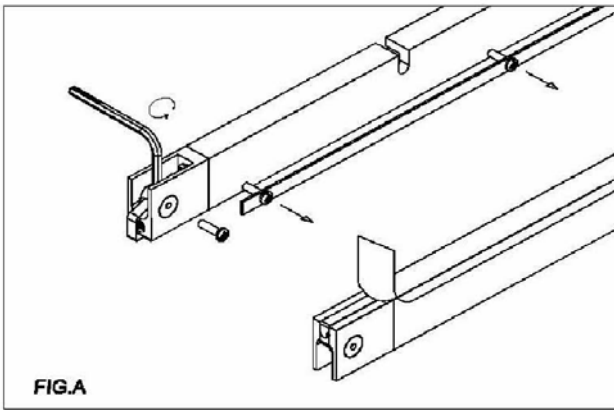

4.4 MAINTENANCE INTERVALS AND CHECK ITEMS

Maintenance Intervals/ Check items	Daily	Bimonthly	Quarterly	Yearly	Biyearly	3 ~ 5 years	Note
Keep the vacuum lid open after finished working and let vacuum pump running about 15 minutes.	X						
Check the oil level	X						
Check the sound of motor	X						
Oil come out from exhaust cover or not	X						
Bottom sealing bar working normally or not	X						
Clean the exhaust filter		X					
Change vacuum oil		X					
Replace exhaust filter				X			
Replace Teflon tape				X			As request
Replace sealing Silicone rubber				X			As request
Replace lid gasket rubber				X			As request
Replace pressure bag					X		As request
Replace vanes						X	

Above-mentioned maintenance intervals are scheduled basically for 8 working hours per day.

Recommended oil :

A. Grav. API	30.5
Pour Pt.	-15°C
Flash Pt.	225°C
Viscosity	32.05 CST@40°C
Color	Light Yellow
V.I.	100

5. TROUBLESHOOTING

5.1 Problems and Corrections

Problem and Corrections - Review installation procedure section to ensure the installation is correct. If correct, the troubleshooting chart below lists possible problems, causes, corrections, and reference guide.

Problem	Cause	Correction
Control panel is under normal function, but vacuum pump does not start.	The KM1, QM1, MCB1, MCB2 protectors are disconnected.	Check each part and turn on the switch, reconnect, if necessary.
Vacuum pump does not run.	The power supply is not corresponding with the power demand indicated on the back of machine.	Reconnect to correct power source.
Insufficient vacuum in chamber.	Low oil level in vacuum pump. Vacuum pump is rotating in wrong direction. Lid silicone rubber damaged.	Fill oil, if necessary. Stop machine immediately. Then alter the power connection and reconnect to correct ones. Replace.
Insufficient vacuum in bag. Note : Mostly insufficient vacuum in bag is due to leakage of bag, but not the fault of machine.	Bag is leaking. Sharp corners on wrapped product puncture the bag. Bag is too large.	Replace the bag. Replace the bag and use a thicker one. Replace with a smaller one.
Vacuum bag is easily pulled apart by hand.	Sealing time (temperature) is too short (low).	Adjust sealing time (temperature) to be longer (higher).
Sealing area has some burnt marks or bubbles appeared.	Sealing area stuffed with oil or meat juice or dirt. Sealing time (temperature) is too long (high).	Clean and remove them. Adjust sealing time (temperature) to be shorter (lower).
Lid does not open.	Vacuum valve is damaged.	Replace it.

Problem	Cause	Correction
<p>No or improper sealing. NOTE : Please do not adjust sealing longer than regular time, or it will reduce the life of Teflon tape and silicone rubber.</p>	<p>Insufficient pressure. Sealing transformer is damaged. Teflon tape or silicone rubber is damaged. Sealing time and cooling time are too short. Sealing pressure is too low. Heating element is loose. Heating element is broken.</p>	<p>Replace it. Tighten it. Pressure bar is damaged, replace it. Replace it. Replace it. Adjust to proper time. Replace the pressure bag.</p>
<p>Lid does not close.</p>	<p>Vacuum valve is damaged. Limit switch is disconnected or damaged.</p>	<p>Replace it. Reconnect or replace it.</p>

6. TROUBLESHOOTING

6.1 PNEUMATIC DIAGRAM

1. Vacuum Gauge	5. Gas Valve
2. Control Panel	6. Vacuum Pump
3. Ventilation Valve	7. Vacuum Valve Set
4. Sealing Valve	8. Pressure Control Valve

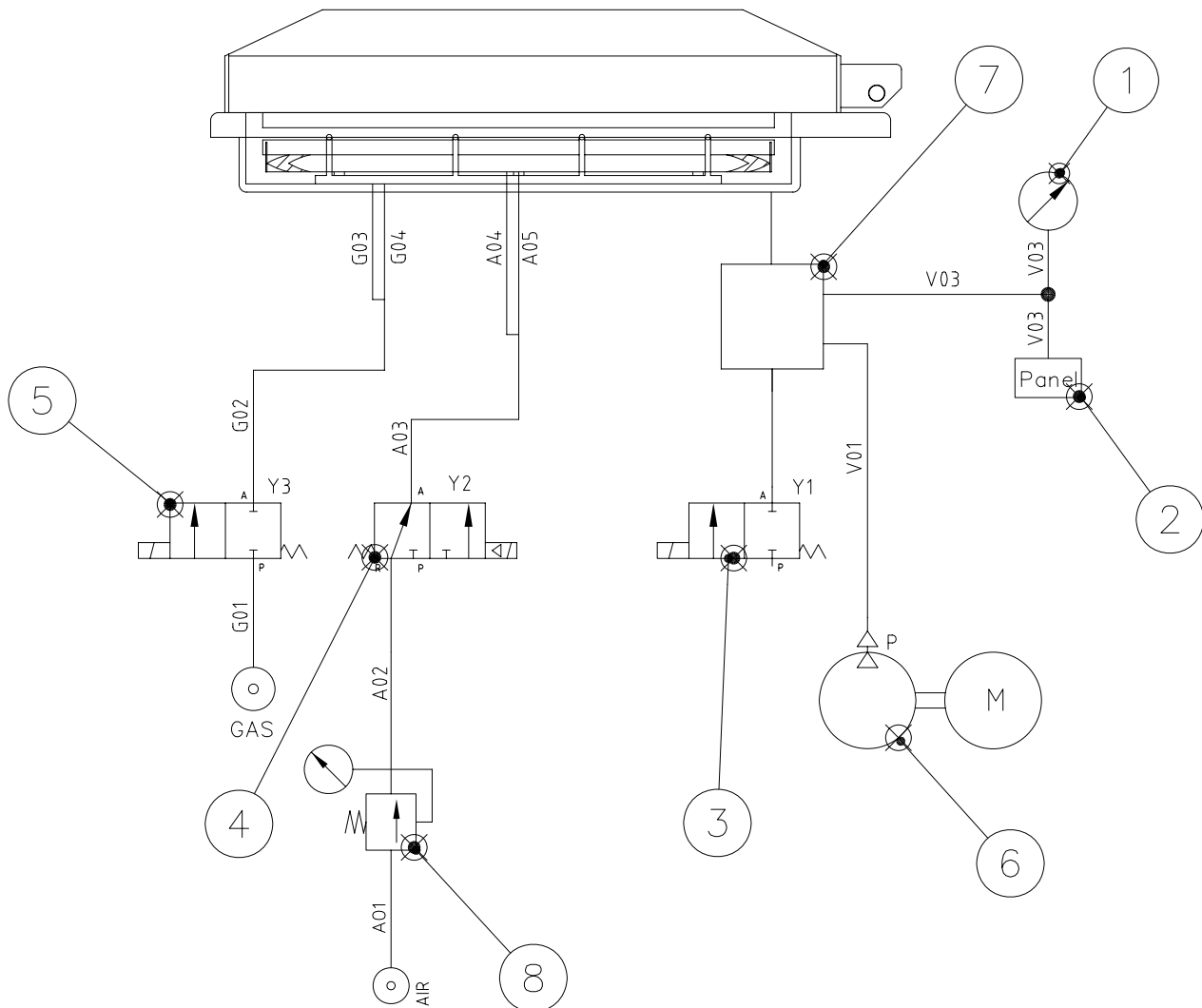

6.2 ELECTRICAL DIAGRAM

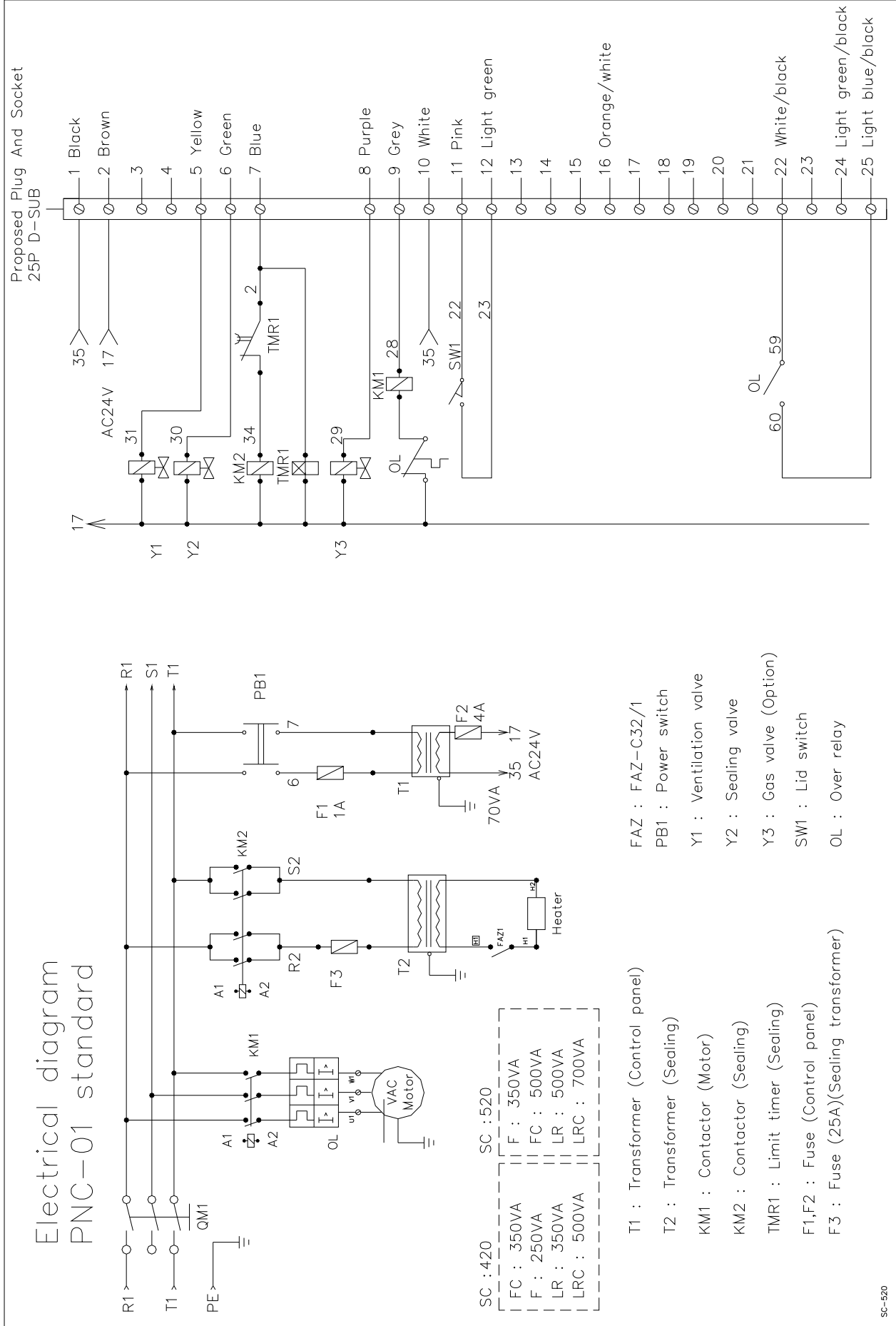

7. FABRICATION

7.4 LID DIAGRAM

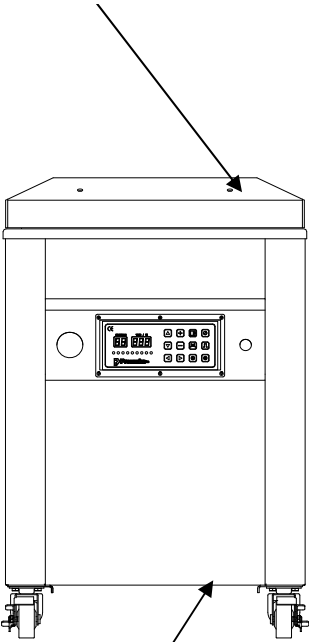

7.2 VACUUM CHAMBER DIAGRAM
7.3 SEALING BAR-STANDARD DIAGRAM

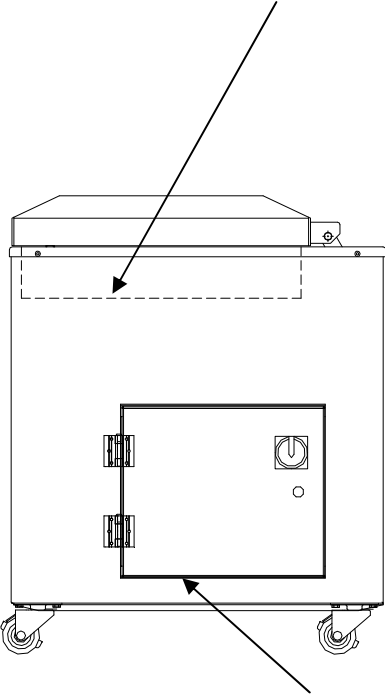

7.1 BODY

7.5 ELECTRICAL BOX

7.1 BODY

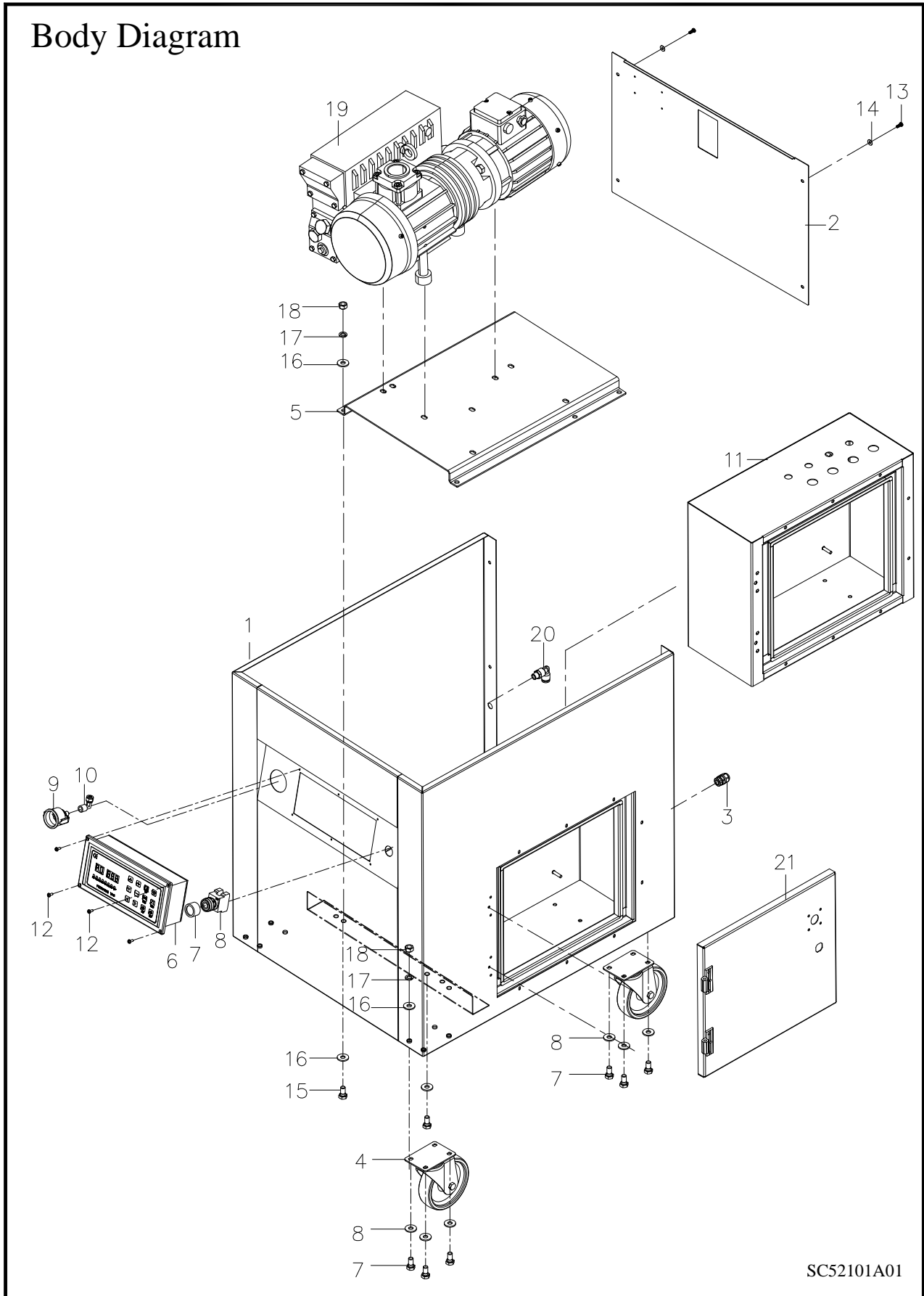

SC52101A01

7.2.1 VACUUM CHAMBER DIAGRAM-LR

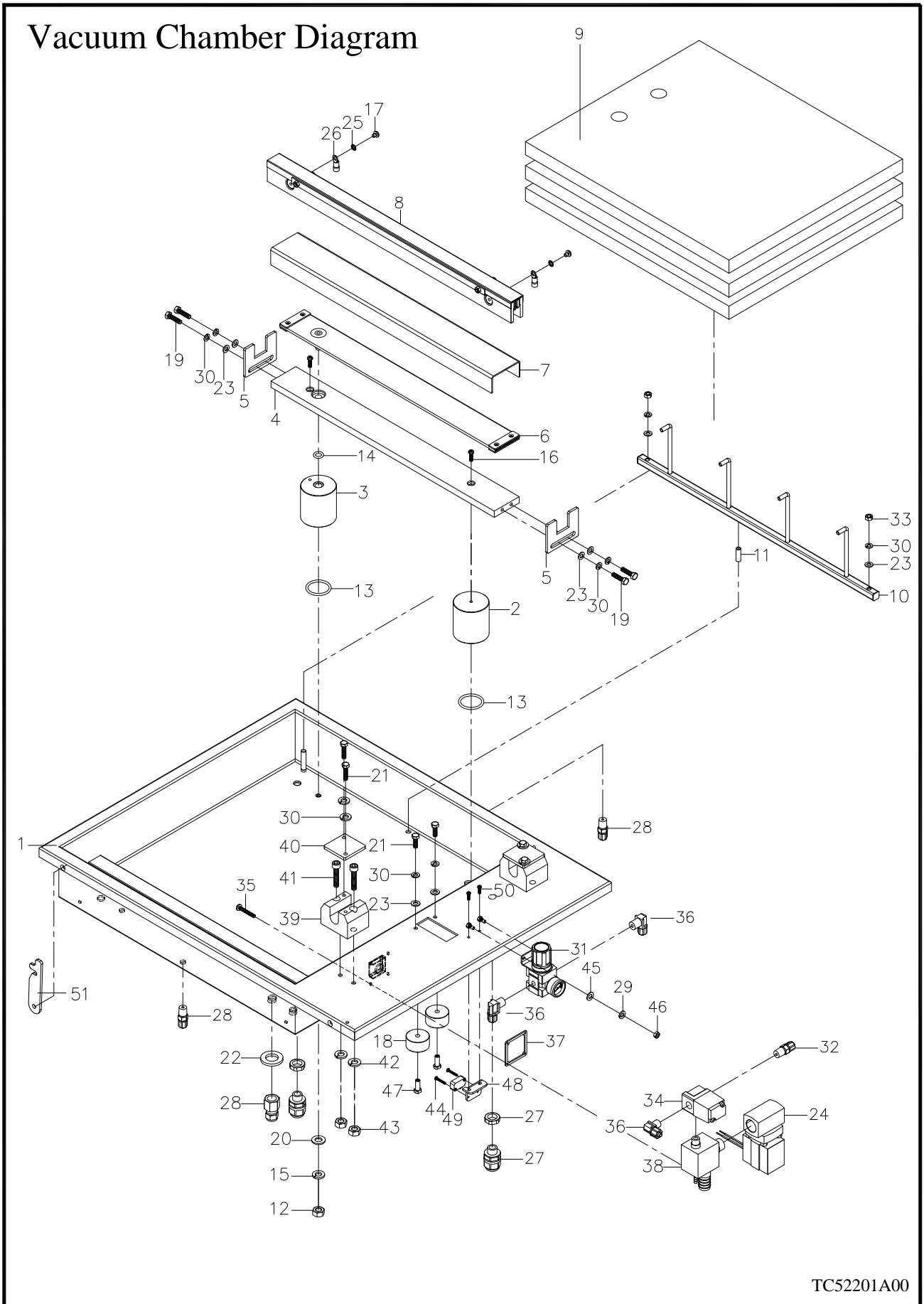

TC52201A00

NO.	PART NO.	DESCRIPTION	Q'TY	NOTE
1	SC52201000	Vacuum chamber	1	
2	TC52210000	Hex busing block holder	2	
3	TC52211000	Hex busing block holder	2	
4	TC52212000	Sealing bar plate	2	
5	VA04213000	Sealing bar holder	4	
6	TC52214A00	Pressure bag	2	
7	TC52219000	Pressure bag holder	2	
8	TC52274A00	Sealing bar - bottom (LR)	2	
	TC52220A00	Sealing bar - bottom (LR-C)		
9	TC52223000	Flat plate	3	
10	TC5241200	Gas nozzle tube	2	
11	VA04241000	Gas inner bushing	2	
12	2707203	Hex nut M8	2	
13	2740168	O-ring	4	
14	2740169	O-ring	2	
15	2705301	Split lock washer M8	2	
16	2703308	Round head screw M4 x 12	4	
17	2703304	Round head screw M4 x 6	4	
18	TC52303000	Roller	2	
19	2700414	Hex head screw M5 x 12	8	
20	2705152	Flat washer M8	2	
21	2700416	Hex head screw M5 x 10	6	
22	2705155	Flat washer M14	2	
23	2705150	Flat washer M5	14	
24	29118081	Solenoid valve	1	
25	2705601	Split lock washer M4	4	
26	2840075	Terminal	4	
27	2861019	Fitting, MG-12A-05G	4	
28	29090311	Copper PU adapter	2	
29	2705306	Split lock washer M4	2	
30	2705303	Split lock washer M5	14	
31	2921211	Mounting rack AR20P-270AS	1	
32	29090313	C type adapter VSC-8x1/4"	1	
33	2707208	Hex nut M5	4	
34	29118015	Solenoid valve VT307-9(B)G-02 AC24V 50/60HZ	1	
35	2703327	Solenoid valve M4 x 20	4	

NO.	PART NO.	DESCRIPTION	QTY	NOTE
36	29090312	L type adapter VSL-8 x PT1/4	3	
37	VA04250010	Plate, Distributing connectorn	1	
38	VA04250000	Distributing connectorn	1	
39	TC52307000	PE lid holder	2	
40	TC52308000	Cover	2	
41	27011551	Round head screw M6 x 35	4	
42	2705302	Split lock washer	4	
43	2707204	Hex nut M6	4	
44	2703323	Round head screw M3 x 20	2	
45	2705154	Flat washer M4	2	
46	27070210	Hex nut M4 x 0.7	2	
47	TC52305001	Shaft roller	2	
48	TC52203000	Valve holder plate	1	
49	2853023	Limit switch	1	
50	27033311	Round head screw M3 x 16	2	
51	TC52227000	Lid clamp	2	

7.2.2 VACUUM CHAMBER DIAGRAM-FB

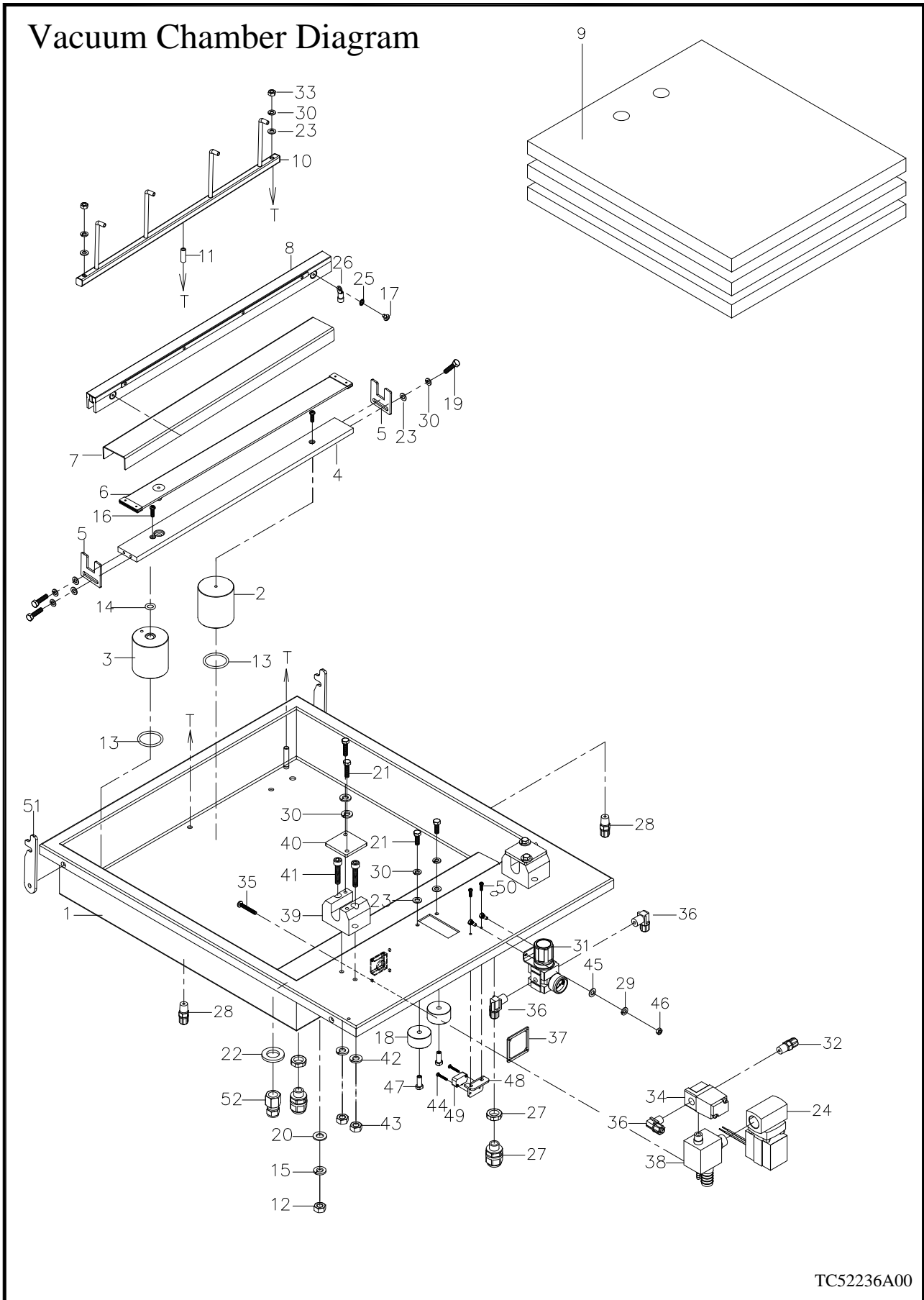

TC52236A00

NO.	PART NO.	DESCRIPTION	Q'TY	NOTE
1	TC52236000	Vacuum chamber	1	
2	TC52210000	Hex busing block holder	2	
3	TC52211000	Hex busing block holder	2	
4	TC52212000	Sealing bar plate	2	
5	VA04213000	Sealing bar holder	4	
6	TC52214A00	Pressure bag	2	
7	TC52219000	Pressure bag holder	2	
8	TC52274A00	Sealing bar - bottom	2	
	TC52220A00	Sealing bar - bottom		
9	TC52237000	Flat plate	3	
10	TC5241200	Gas nozzle tube	2	
11	VA04241000	Gas inner bushing	2	
12	2707203	Hex nut M8	2	
13	2740168	O-ring	4	
14	2740169	O-ring	2	
15	2705301	Split lock washer M8	2	
16	2703308	Round head screw M4 x 12	4	
17	2703304	Round head screw M4 x 6	4	
18	TC52303000	Roller	2	
19	2700414	Hex head screw M5 x 12	8	
20	2705152	Flat washer M8	2	
21	2700416	Hex head screw M5 x 10	6	
22	2705155	Flat washer M14	2	
23	2705150	Flat washer M5	14	
24	29118081	Solenoid valve	1	
25	2705601	Split lock washer M4	4	
26	2840075	Terminal	4	
27	2861019	Fitting, MG-12A-05G	4	
28	29090311	Copper PU adapter	2	
29	2705306	Split lock washer M4	2	
30	2705303	Split lock washer M5	14	
31	2921211	Mounting rack AR20P-270AS	1	
32	29090313	C type adapter VSC-8x1/4"	1	
33	2707208	Hex nut M5	4	
34	29118015	Solenoid valve VT307-9(B)G-02 AC24V 50/60HZ	1	
35	2703327	Solenoid valve M4 x 20	4	

7.3.1 SEALING BAR-STANDARD DIAGRAM-FLR-C

Sealing Bar-Standard Diagram

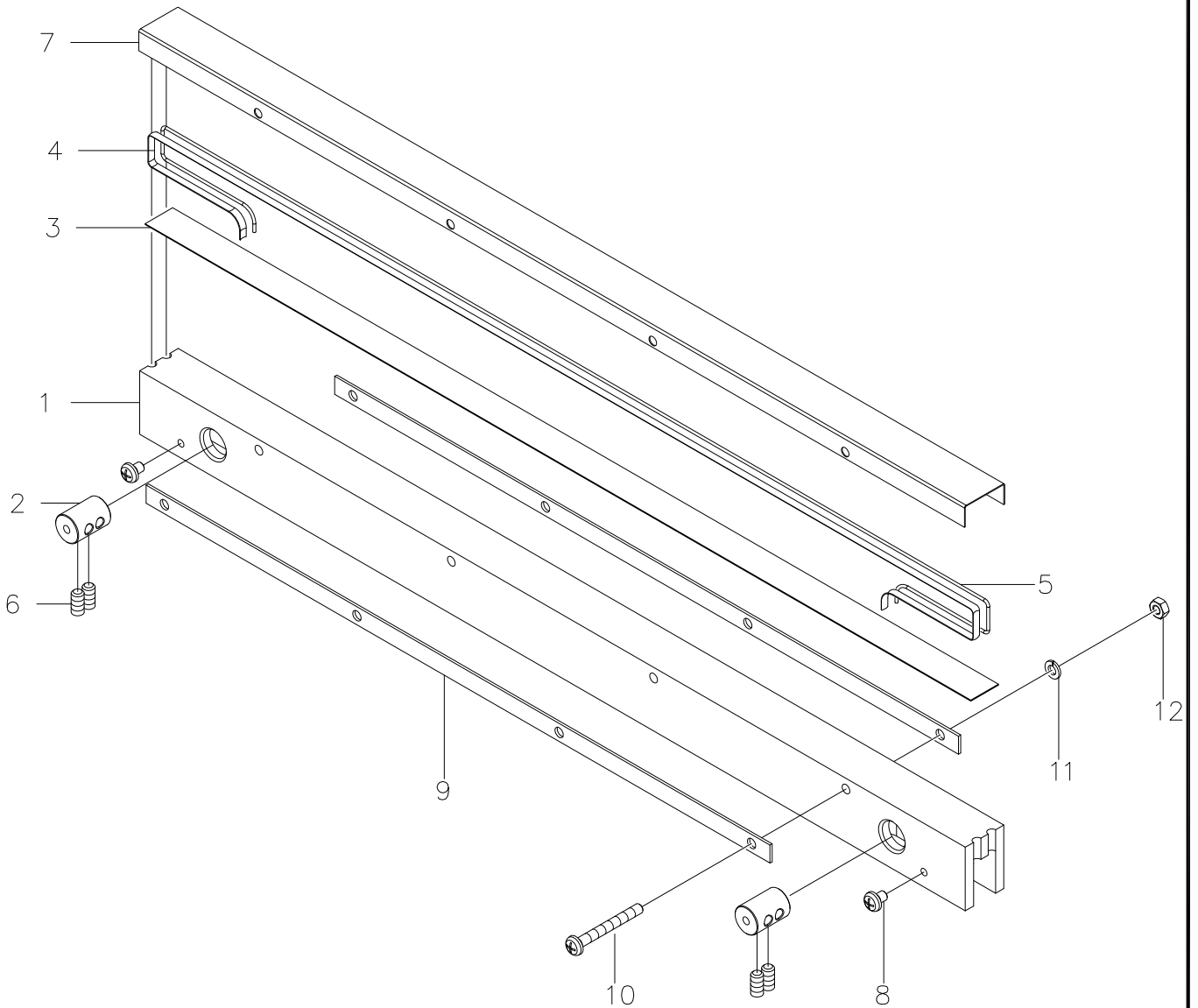

TC52220A00

7.3.2 SEALING BAR-STANDARD DIAGRAM-FLR

Sealing Bar-Standard Diagram

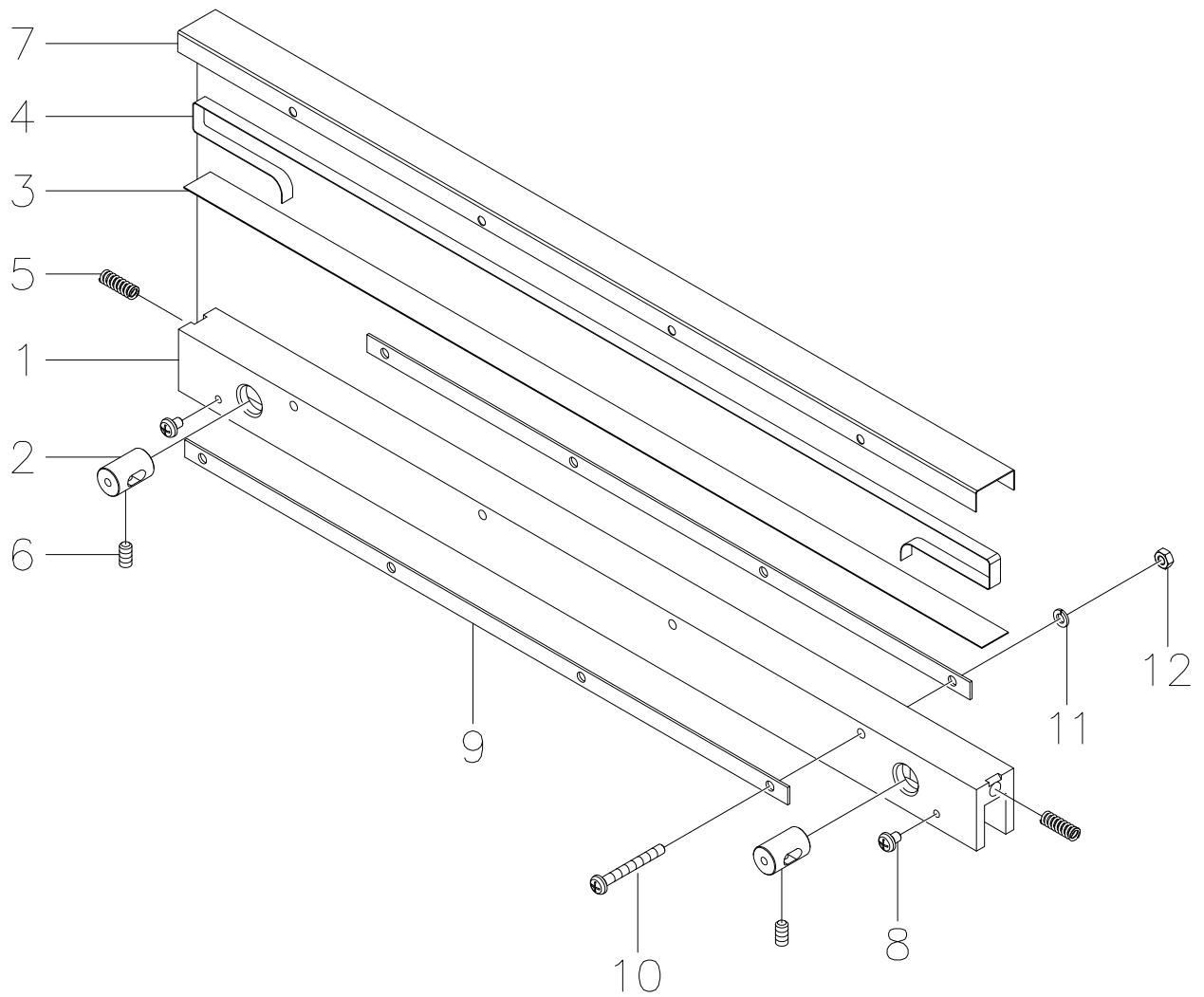

TC52274A00

7.4 LID DIAGRAM

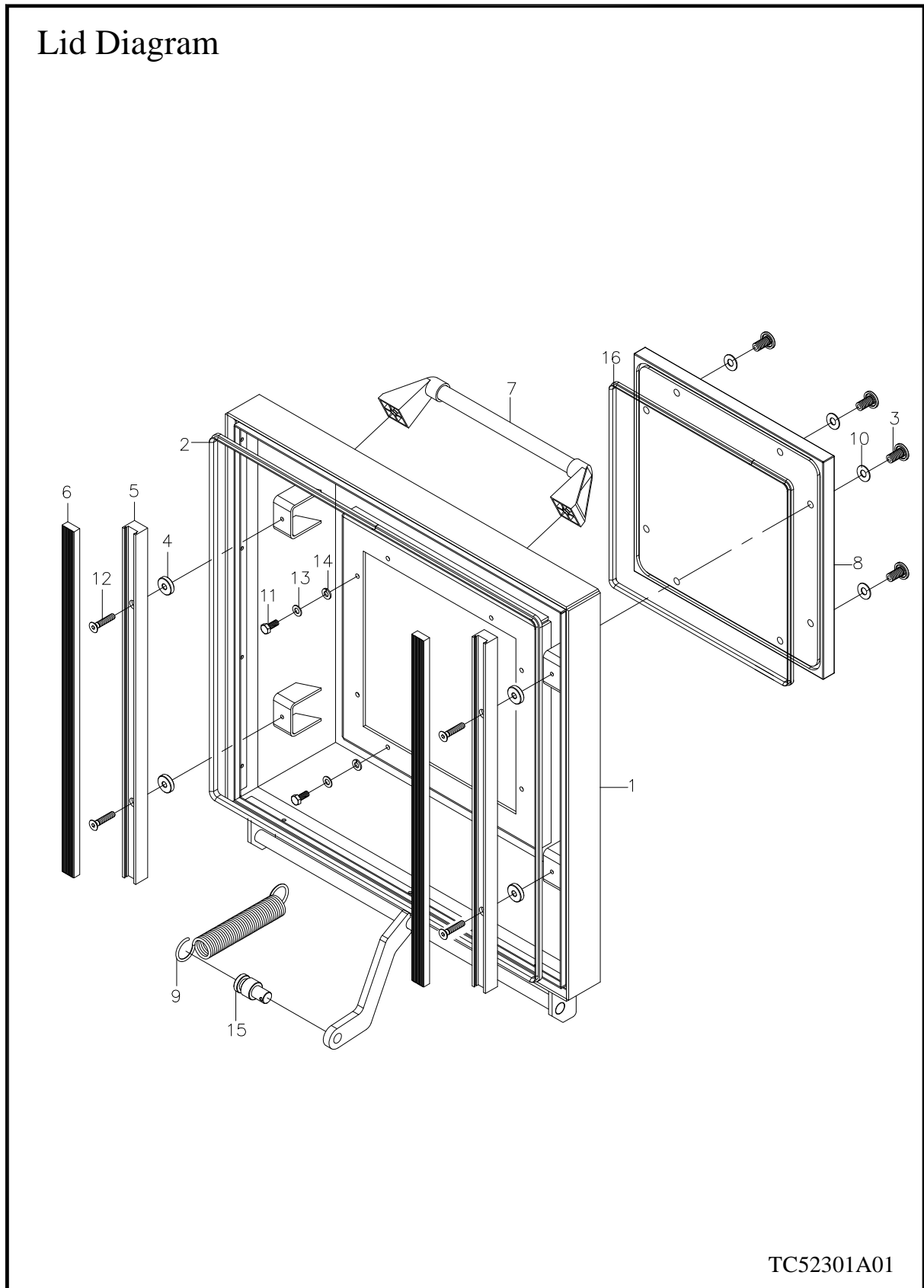

7.4 LID DIAGRAM(FB)

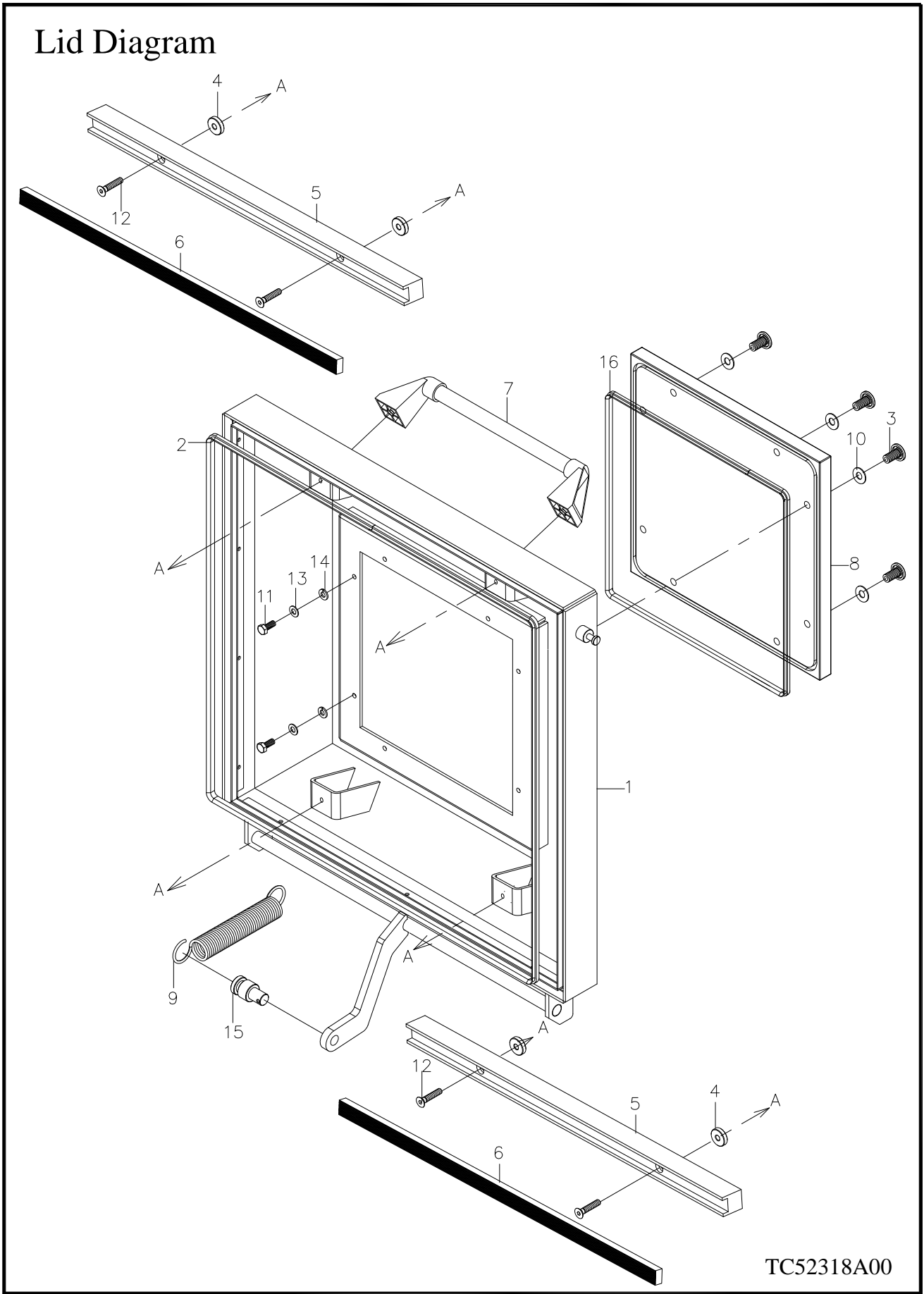

TC52318A00

7.5 ELECTRICAL BOX

STANDARD

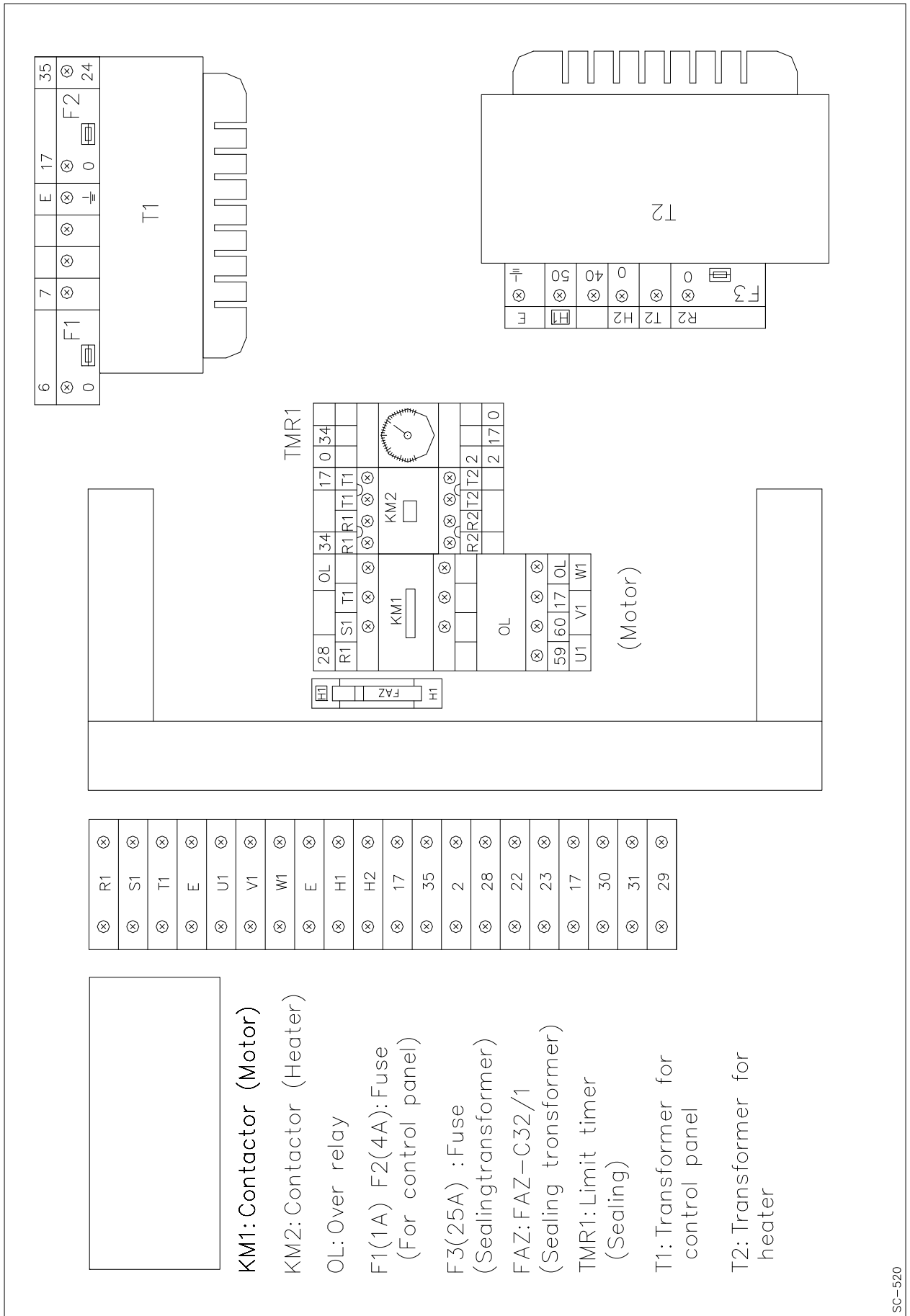

ITEM	PART NO.	DESCRIPTION	SPECIFICATION	Q'TY	NOTE
KM1	2810739	Contactator	3A1a CN-11-B5 (AC24V)	1	
KM2	2810758	Contactator	CU-18/4P-4A (AC24V)	1	
OL	2811538	Overload Relay	RHU-10K1(11.3~16A)	1	1 § 110V
	2811535		RHU-10K1(5.5~7.5A)	1	1 § 220V
F1	2890048	Fuse	20mm 1A	1	
F2	2811659	Fuse	20mm 4A	1	
F3	2890069	Fuse	20mm 25A	1	
F4	28960066-1	Fuse	30mm 30A	2	
	2890022	Cover, Horizontal Fuse	TFB101N	2	
	2890023	Fuse Holder	SF-111A	2	
R1	2833328	Time Relay	ANLY AMY-2 6S AC24V	1	
	2833329	Socket Relay	PYF08A-E MY2	1	
	2850636	Hook	PYC-A1	2	
T1	28960010	Transformer	70VA 0F-110-220-240V/ 0F-24V UL	1	110V
T2	28960055	Transformer	700VA 0F-110V/ 0-40-50V UL	1	SC-LRC
	28960050		500VA 0F-110V/ 0-45V UL	1	SC-LR
	28960069		700VA 0F-220-240V/ 0-40-50 UL	1	220V
T.B	2843212	Terminal Block	PUT-10 (17~29)	10	
	2843209	Terminal Block	PTU-30 (R1~H2)	10	
	2843210	Plate, Terminal Block	PTU-30L2	1	
	2843207	Brake, Terminal Block	SBN-20	2	
POWER	2896515	Power Supply	MT S-50-24	1	Option
T.B	2843201	Terminal Block	PUT-20 (17~29)	2	Option
FAZ	2801734	Breaker	FAZ-C32/1	1	